

SERVICE LETTER

DATE: 9 NOVEMBER 2009
PAGE 1 OF 2

LANDING GEAR DAMPER ASSEMBLY AND SEALING COMPOUND

MODELS AFFECTED: All MD900 helicopters.

This Service Letter is issued to tell owners and operators to be careful when the corrosion inhibitive sealing compound (C211) is applied to the landing gear damper assembly. Sealing compound (C211) is applied to external mating parts and all fasteners. Too much sealing compound (C211) can cause a blockage in the drain ports of the damper assembly (ref. Figure 1). The drain ports let moisture exit the damper assembly. Blocked drain ports can cause internal corrosion in the damper assembly. Corrosion can reduce the function and life of the damper assembly.

During installation of the damper assembly, be careful not to cover the four drain ports with sealing compound (C211) (ref. CSP-900RMM-2, 32-00-00, Landing Gear Damper Assembly Installation). Apply masking tape to the drain ports during installation of the damper assemblies to prevent blockage. Remove masking tape after the sealing compound has cured.



Do not damage adjacent material if it is necessary to remove sealing compound (C211).

Inspect the damper assemblies at the next inspection to make sure there is no blockage. If there is blockage, use a brush or scribe or other tool to remove unwanted sealing compound (C211) from the drain ports. Make sure the drain ports are not clogged with unwanted material after repair.

For further assistance, contact the Field Service Department at MDHI, Mesa, Arizona. Telephone 1-800-388-3378 or (480) 346-6387. DATAFAX: (480) 346-6813.

Legend (Ref. Figure 1)

1. DAMPER ASSY
2. AFT CROSSTUBE
3. SKID TUBE ASSY
4. FLAT WASHER
5. COUNTERSUNK WASHER
6. BOLT
7. NUT
8. FLAT WASHER
9. COUNTERSUNK WASHER
10. BOLT
11. NUT
12. FLAT WASHER
13. BOLT

DATE: 9 NOVEMBER 2009
 PAGE 2 OF 2

SERVICE LETTER

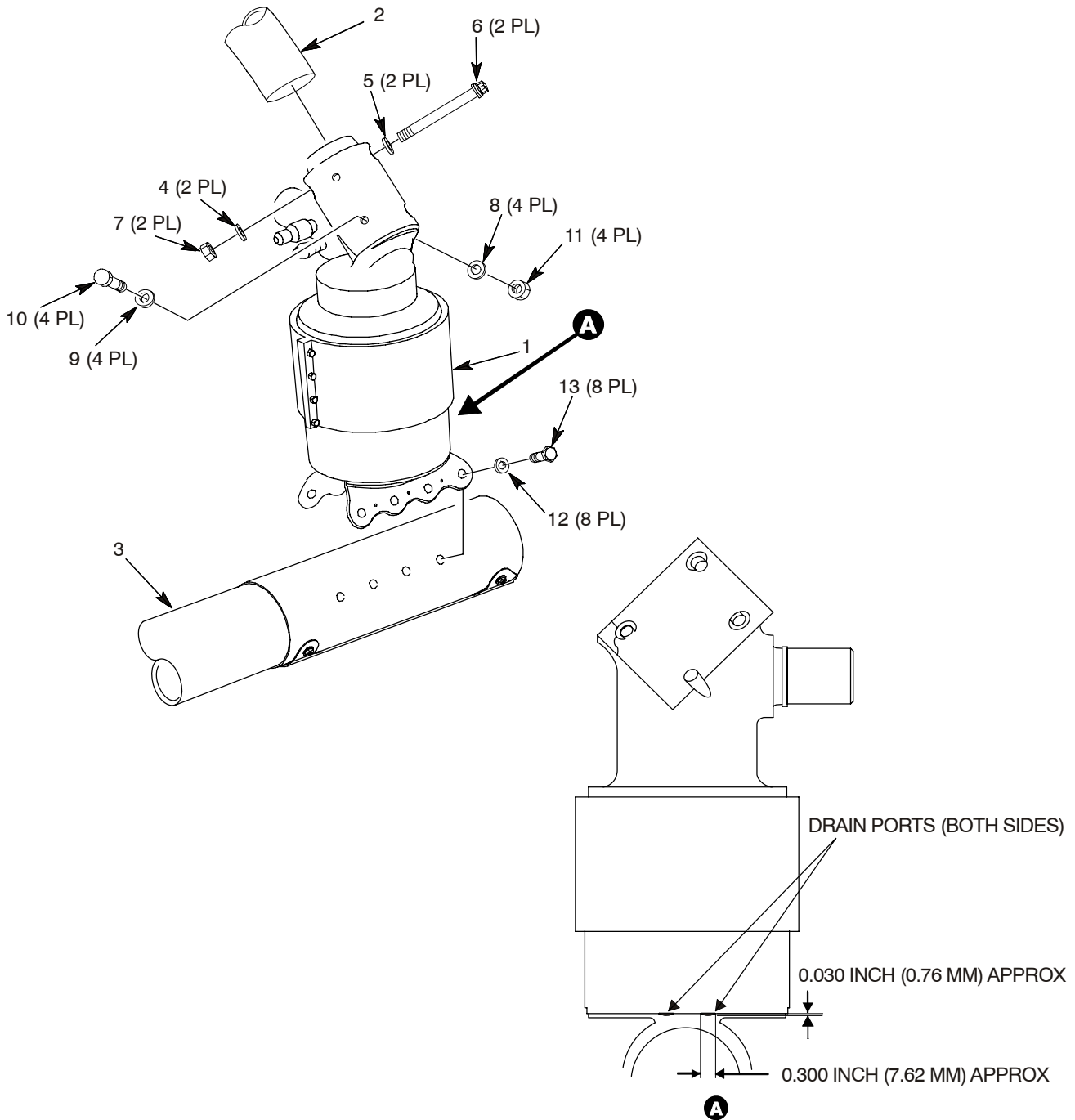

9L02-067

Figure 1. Location of Drain Ports and Installation of Damper Assembly

Copyright 1999-2009 by MD Helicopters Inc.
 This document may be reproduced and distributed provided no fee is charged,
 the text is not modified, and this copyright notice is included.