



SERVICE LETTER

DATE: 29 JUNE 2000

PAGE 1 OF 2

ANTI-TORQUE FAN INLET SCREEN

TO: ALL OWNERS AND OPERATORS OF MD-900 HELICOPTERS.

This Service Letter is issued to advise all owners and operators of possible cracks occurring in certain P/N 900F2611850-101 anti-torque fan inlet screens. These screens can be identified by weld beads between the mesh on the aft screen frame and weld beads on the screen itself (Ref. Figure 1).

If any of these screens are found or any broken strands are noted during the pilot's daily preflight check or any maintenance activity, contact the Field Service Department at MDHI, Mesa, Arizona by telephone at (800) 388-3378 or (480) 346-6387 for information on obtaining a replacement screen.

SERVICE LETTER

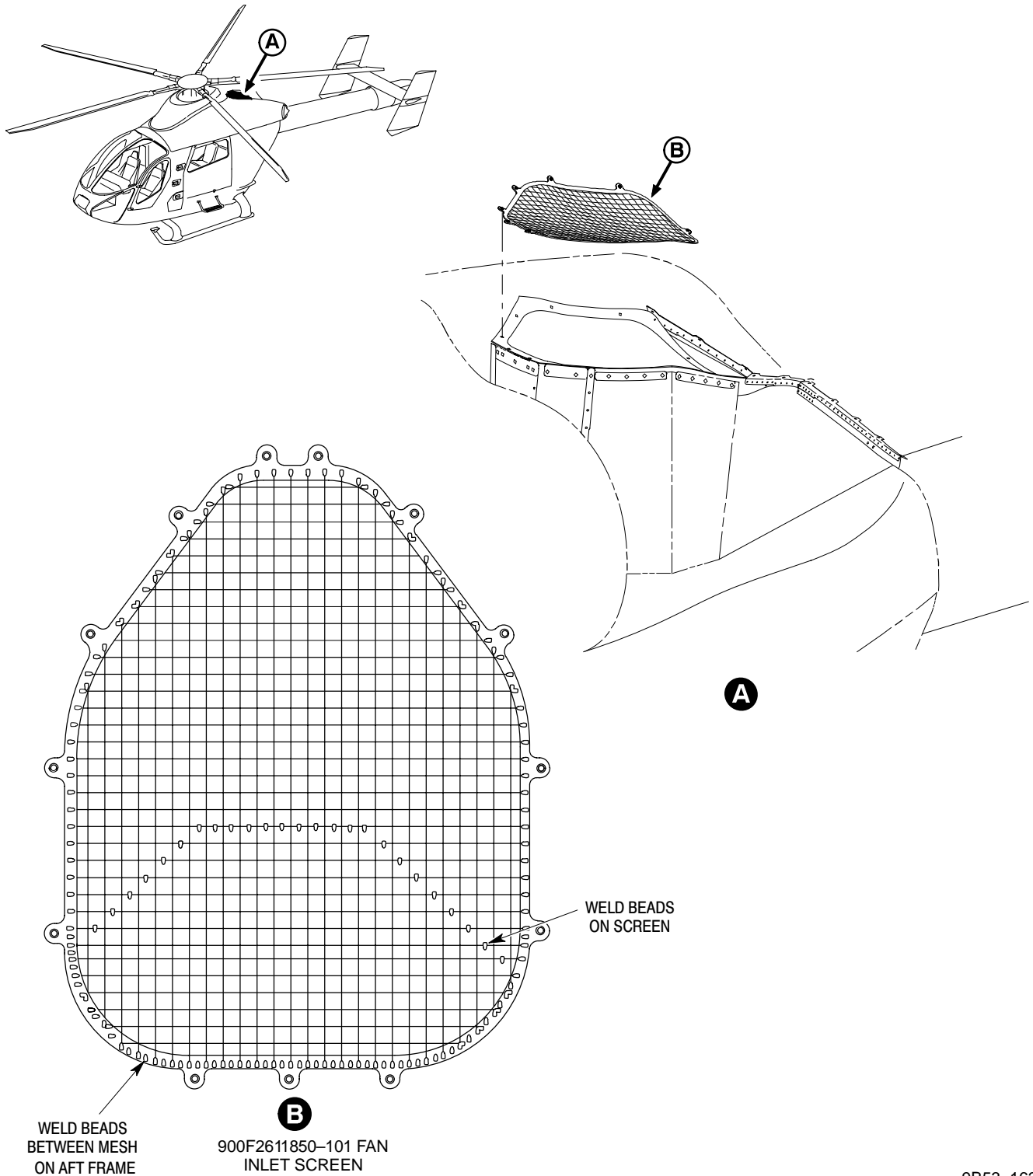

9B53-162

Figure 1. Anti-Torque Fan Inlet Screen