

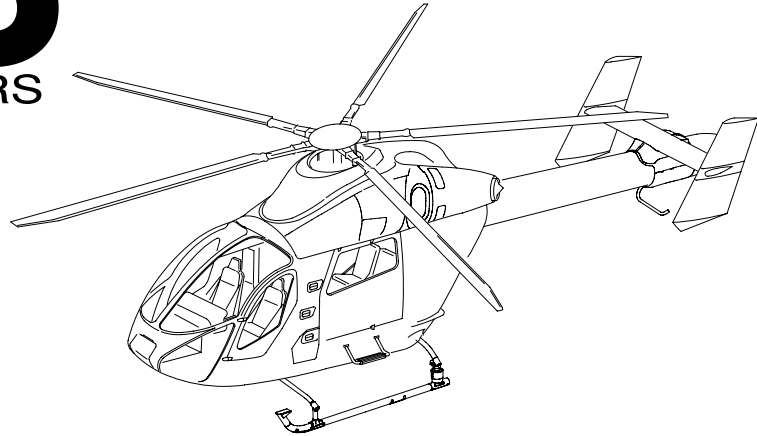

CSP-902RFM207E-1



**European Aviation Safety Agency approved  
Rotorcraft Flight Manual for Model MD900  
(902 Configuration with PW 207E)**

As of 28 September 2003, the EASA began approving FAA rotorcraft flight manuals. Operators of MD900 series helicopters registered in a European Union member state are required to place this approval page after the cover page in their flight manual.

**Log of EASA Revisions By Date**

REVISION NUMBER AND DATE	EASA Approval Number
Revision 7 ..... 13 January 2003	2004-2053
Revision 8 ..... 8 July 2005	2004-2053
TR6-001 ..... 5 June 2006	E02686
TR6-002 ..... 22 December 2006	E02686
Revision 9 ..... 21 August 2007	E02686
Revision 10 ..... 20 February 2008	E02686
Revision 11 ..... 11 April 2008	E02686
<b>Reissue #1 ..... 2 December 2008</b>	E02686
Revision 1 ..... 21 July 2009	E02686
<b>Reissue #2 ..... 6 November 2009</b>	E02686

EASA-i/( EASA-ii blank)

Reissue #2

Punch holes in circles.

Cut  along dashed lines.

