

# TECHNICAL BULLETIN

DATE: 12 DECEMBER 2011

PAGE 1 OF 28

\* Supersedes Technical Bulletin TB600-007R2, dated 05 October 2006. Revised to continue the “special pricing” of TB600-007R2 and remove the deadline date. This credit covers the cost for parts and labor associated with TB600-007R3. Aircraft that are in compliance with TB600-007R1 and TB600-007R2 meet the intent of this revision.

Completion of this bulletin eliminates the requirements of SB600N-039, or latest revision.

## FUSELAGE AFT SECTION AND TAILBOOM MODIFICATION

### 1. PLANNING INFORMATION

#### A. Aircraft Affected:

Model 600N Helicopters, serial number RN003 thru RN066 and RN068.

#### B. Assembly/Components Affected By This Bulletin:

Tailboom Attach Fitting (P/N 500N3422-BSC, -3), Longeron (P/N 500N3120-3, -4),  
Tailboom Assembly (P/N 600N3500-503, -505, -507, -509).

#### C. Reason:

Analysis of the lower tailboom attach fittings and the upper longerons indicate that cracks may occur.

Failure to comply with this Bulletin may result in loss of tailboom and control of the helicopter.

#### D. Description:

Procedures in this Bulletin provide owners and operators with information pertaining to modification of the fuselage aft section (in accordance with MDHI Modification Drawing 600N3100) to strengthen tailboom attach fittings and upper longerons. A high level of sheet metal expertise and experience is required to perform this modification.

#### E. FAA Approval:

The technical design aspects of this Bulletin are FAA Approved.

#### F. Manpower: Approximately 300 man-hours are required to complete this Bulletin when accomplished in conjunction with a major or annual inspection. Man-hours are based on “hands-on” time and may vary based on personnel and facilities available.

#### G. Time of Compliance

Customer option, at owner/operator’s discretion.

DATE: 12 DECEMBER 2011  
 PAGE 2 OF 28

# TECHNICAL BULLETIN

## H. Tooling:

Contact MDHI for tooling availability.

Contact Fatigue Technology, Inc. for instructions on use of tooling.

TOOLS AND EQUIPMENT		
Nomenclature		Source
4-0-N Sized Tooling:		MDHI
<u>PART NUMBER</u>	<u>DESCRIPTION</u>	or
CBG-4-0-N-1	Combination Gage	
CBM-4-0-N-1-30-V1	Mandrel	
CBR-4-0-N-1-.1280	Gage Finish Reamer	Fatigue Technology Inc.
CBSD-4-0-N-1	Starting Drill	401 Andover Park East
CBSR-4-0-N-1	Starting Reamer	Seattle, WA 98188
MEN-14A-0401F	Nosecap Assembly	(206) 246-2010
CBMG-4-0-N	Mandrel Check Fixture	sales@fatiguetech.com
LB-20	2305-003 Puller Assembly	
FT-20	2677-001 FT-20 Pump Assembly	
4-2-N Sized Tooling:		MDHI
<u>PART NUMBER</u>	<u>DESCRIPTION</u>	or
CBG-4-2-N-1	Combination Gage	
CBM-4-2-N-1-30-V1	Mandrel	
CBR-4-2-N-1-.1590	Gage Finish Reamer	Fatigue Technology Inc.
CBSD-4-2-N-1	Starting Drill	401 Andover Park East
CBSR-4-2-N-1	Starting Reamer	Seattle, WA 98188
MEN-14A-0423F	Nosecap Assembly	(206) 246-2010
CBMG-4-2-N	Mandrel Check Fixture	sales@fatiguetech.com
LB-20	2305-003 Puller Assembly	
FT-20	2677-001 FT-20 Pump Assembly	
Nutplate Retainer Installation Tooling:		MDHI
<u>MODEL</u>	<u>PART NO./DESCRIPTION</u>	or
FTSD-6-0-3-C	1017-639 Starting Drill	
FTSR-6-0-3-C	1018-921 Reamer	
FTN-6-0-3	5192-035 FYCX Nosecap	Fatigue Technology Inc.
FTG-6-0-3	2072-859 Combination Gage	401 Andover Park East
FTGM-6-0-3	2843-318 Mandrel Check Gage	Seattle, WA 98188
FTM-6-0-3-8	5200-053 Mandrel FTCX	(206) 246-2010
LB-20	2305-003 Puller Assembly	sales@fatiguetech.com
FT-20	2677-001 FT-20 Pump Assembly	
600N3510-1-DJ1	Drill Fixture	MDHI

# TECHNICAL BULLETIN

DATE: 12 DECEMBER 2011

PAGE 3 OF 28

## I. Material/Part Availability:

Owners/operators who comply with this Bulletin are eligible for special pricing for parts, labor credit and technical assistance. Contact MDHI Parts Sales Dept. for price and parts availability.

Parts marked with an asterisk (\*) are included in Kit, P/N TBK007. Contact MDHI Parts Sales Dept. or Warranty and Repair Dept., as applicable. Other parts/supplies may be purchased locally from commercial sources.

REPLACEMENT PARTS/SUPPLIES			
Nomenclature	Part No.	Qty.	Source
*Clip	500N3427-7	6	MDHI
*Clip	500N3427-9	2	MDHI
*Angle	500N3120-9	1	MDHI
*Angle	500N3120-10	1	MDHI
*Longeron	600N3120-1	1	MDHI
*Longeron	600N3120-2	1	MDHI
*Angle	600N3121-1	1	MDHI
*Angle	600N3121-2	1	MDHI
*Spacer	600N3122-3	2	MDHI
*Angle	600N3123-1	1	MDHI
*Angle	600N3123-2	1	MDHI
*Angle	600N3124-1	1	MDHI
*Angle	600N3124-2	1	MDHI
*Fitting	600N3130-3	2	MDHI
*Strut	600N3130-5	1	MDHI
*Fitting	600N3422-1	4	MDHI
*Bracket	500N3429-9	1	MDHI
*Bracket	500N3429-10	1	MDHI
*Doubler	500N3127-21	1	MDHI
Rivet	MS20470AD3-1	6	Commercial
Rivet	MS20470AD4-28	6	Commercial

DATE: 12 DECEMBER 2011  
PAGE 4 OF 28

# TECHNICAL BULLETIN

REPLACEMENT PARTS/SUPPLIES (Cont.)			
Nomenclature	Part No.	Qty.	Source
Rivet	MS20470AD4-3	10	Commercial
Rivet	MS20470AD3-3	200	Commercial
Rivet	MS20470AD3-4	200	Commercial
Rivet	MS20470AD4-4	100	Commercial
Rivet	MS20615-5M3	20	Commercial
Rivet	MS20615-5M7	20	Commercial
Rivet	MS20615-5M6	12	Commercial
Rivet	MS20615-4M3	4	Commercial
Rivet	MS20615-4M4	48	Commercial
Rivet	MS20615-4M5	128	Commercial
Rivet	MS20426AD3-7	8	Commercial
Rivet	MS20426AD4-3	18	Commercial
Rivet	NAS1919B04S02	58	Commercial
Rivet	NAS1919B05S02	4	Commercial
Rivet	NAS1919B04S03	120	Commercial
Rivet	NAS1919B04S04	120	Commercial
Rivet	NAS1921B04S02	25	Commercial
Rivet	NAS1921B04S03	25	Commercial
Rivet	MS20426A4-1	8	Commercial
Rivet	MS20427M5-4	8	Commercial
Rivet	NAS1097AD3-5	36	Commercial
Rivet	NAS1720KE4L2A	76	Commercial
Rivet	NAS1738B4-6	20	Commercial
*Pin Rivet	MHS5605-5-5	16	MDHI
*Pin Rivet	MHS5603-5-3	3	MDHI
*Pin Rivet	MHS5603-5-7	7	MDHI

# TECHNICAL BULLETIN

DATE: 12 DECEMBER 2011

PAGE 5 OF 28

REPLACEMENT PARTS/SUPPLIES (Cont.)			
Nomenclature	Part No.	Qty.	Source
*Collar	MHS5583-5	4	MDHI
*Collar	MHS5582-5	22	MDHI
Bolt	NAS6603-16	1	Commercial
Washer	NAS1149F0363P	1	Commercial
Spacer	NAS43DD3-45	1	Commercial
Clamp	AN742-12	1	Commercial
Nutplate	MS21075L3	4	Commercial
Ty-wrap	MS3367-2-0	4	Commercial
*Retainer, Nutplate	FTR-771-603-.280-S	4	Fatigue Technology, Inc.
Nutplate	NAS1794C6-1	4	Commercial
*Bolt	MHS5482-6H18	4	MDHI
Washer	NAS1587-6C	2	Commercial
*Sleeve	CBS-4-0-N-16F	12	Fatigue Technology, Inc.
*Sleeve	CBS-4-2-N-16F	12	Fatigue Technology, Inc.
*Sleeve	FTS-6-0-3-8	4	Fatigue Technology, Inc.
Rivet	MS20605R3W2 or NAS9302B-2 or CR3212-4	8	Commercial
*ID Plate	MHS4951-1	1	MDHI
Chemical Coating (MIL-C-5541)	Iridite 14-2 Al-Coat Alodine 1201	AR	Commercial
Primer (MIL-P-23377, TI, CC or TII)		AR	Commercial
Sealing Compound (Fuel Resistant)	Pro-Seal 890	AR	Product Research and Chemical Co. 5426 San Fernando Rd Glendale, CA 91209

DATE: 12 DECEMBER 2011  
 PAGE 6 OF 28

# TECHNICAL BULLETIN

REPLACEMENT PARTS/SUPPLIES (Cont.)			
Nomenclature	Part No.	Qty.	Source
Adhesive, Epoxy (MDM 16-1068, C1)	EA9330.3	AR	Dexter Adhesive & Coating Systems 2850 Willow Pass Rd P.O. Box 312 Bay Point, CA 94565-0031 (925) 458-8000 (800) 424-9300
Adhesive, Epoxy (MDM 16-1068, C7)	EA9309.3	AR	Dexter Adhesive & Coating Systems 2850 Willow Pass Rd P.O. Box 312 Bay Point, CA 94565-0031 (925) 458-8000 (800) 424-9300
Epoxy, Clear	Epibond1217	AR	Vantico, Inc. 4917 Dawn Avenue East Lansing MI 48823 (800) 367-8793

## **J. Weight and Balance:**

MODIFICATION	WEIGHT Pounds (kg)	LONGITUDINAL ARM Inches (cm)	LATERAL ARM Inches (cm)
Fuselage Aft Section Modification	4.25 (1.93)	165.5 (420.37)	0 (0)

## **K. Warranty Policy:**

Standard warranty applies.

## **L. Interchangeability:**

None

## **M. Electrical Load Data:**

N/A

## **N. Other Publications Affected:**

Basic Handbook of Maintenance Instructions, Servicing and Maintenance (CSP-HMI-2).  
 Illustrated Parts Catalog (CSP-IPC-4).

*Copyright 1999-2010 by MD Helicopters Inc.  
 This document may be reproduced and distributed provided no fee is charged,  
 the text is not modified, and this copyright notice is included.*

# TECHNICAL BULLETIN

DATE: 12 DECEMBER 2011

PAGE 7 OF 28

## O. Points of Contact

For further assistance:

Field Service Department  
Telephone 1-800-388-3378 or (480) 346-6387.  
DATAFAX: (480) 346-6813.

Spare Parts Sales Department  
Telephone 1-800-388-3378 or (480) 346-6377.  
DATAFAX: (480) 346-6821.

## 2. ACCOMPLISHMENT INSTRUCTIONS



A high level of sheet metal expertise and experience is required to perform this modification.

### A. Preparation

- (1). Remove fan air inlet screen (Ref. CSP-HMI-2, Section 53-30-30, Fan Air Inlet Screen Removal).
- (2). Remove engine plenum access cover (Ref. CSP-HMI-2, Section 53-30-30, Engine Plenum Access Cover Removal).
- (3). Remove fan hub fairing and transmission cover (Ref. CSP-HMI-2, Section 53-30-30, Fan Hub Fairing and Transmission Cover Removal).
- (4). Remove fan inter-connect drive shaft (Ref. CSP-HMI-2, Section 63-15-30, Fan Inter-Connect Drive Shaft Removal)
- (5). Remove anti-torque fan liner (Ref. CSP-HMI-2, Section 64-25-30, Anti-Torque Fan Liner (Felt Metal Seal) Removal).

(Ref. Figure 1)

- (6). Remove fairings



Do not exceed 160° F (71° C) when heating fairings.

- (a). Apply heat and use a wedge to separate upper fairing (P/N 500N3200-3 and fairing assembly (P/N 500N3200-33) from forward lower end of fairing (P/N 500N3125-3).
- (b). If necessary, apply heat to adhesive bonding fairing (P/N 500N3125-73) and fairing (P/N 500N3125-3) to ring (P/N 500N3125-35) and fan support. Remove fairing (P/N 500N3125-35) and ring. Remove leg fairings (P/N 500N3432-3, -11).
- (c). Remove rivets attaching upper fairing (P/N 500N3200-3) to longerons and fan support frame.
- (d). Soften adhesive by applying heat and remove upper fairing (P/N 500N3200-3).

*Copyright 1999-2010 by MD Helicopters Inc.*

*This document may be reproduced and distributed provided no fee is charged, the text is not modified, and this copyright notice is included.*

DATE: 12 DECEMBER 2011  
PAGE 8 OF 28

# TECHNICAL BULLETIN

- (e). Remove fairing assembly (P/N 500N3200-33).
  - 1). Remove rivets attaching fairing assembly to fan support frame.
  - 2). Apply heat to bottom of forward lower edge of fairing assembly) and peel fairing away from flange.
  - 3). Apply heat to sides of fairing assembly and peel fairing away from stringers.
  - 4). Apply heat to top of aft lower edge of fairing assembly and separate from fan support frame using skin wedge.
  - 5). Remove and discard rivets, pins, collars, two fittings (P/N 500N3130-3) and tube (P/N 500N3130-7). (Ref. Figure 2, View C-C).
  - 6). Remove fairing assembly from helicopter. (Ref. Figure 1.)

# TECHNICAL BULLETIN

DATE: 12 DECEMBER 2011  
PAGE 9 OF 28

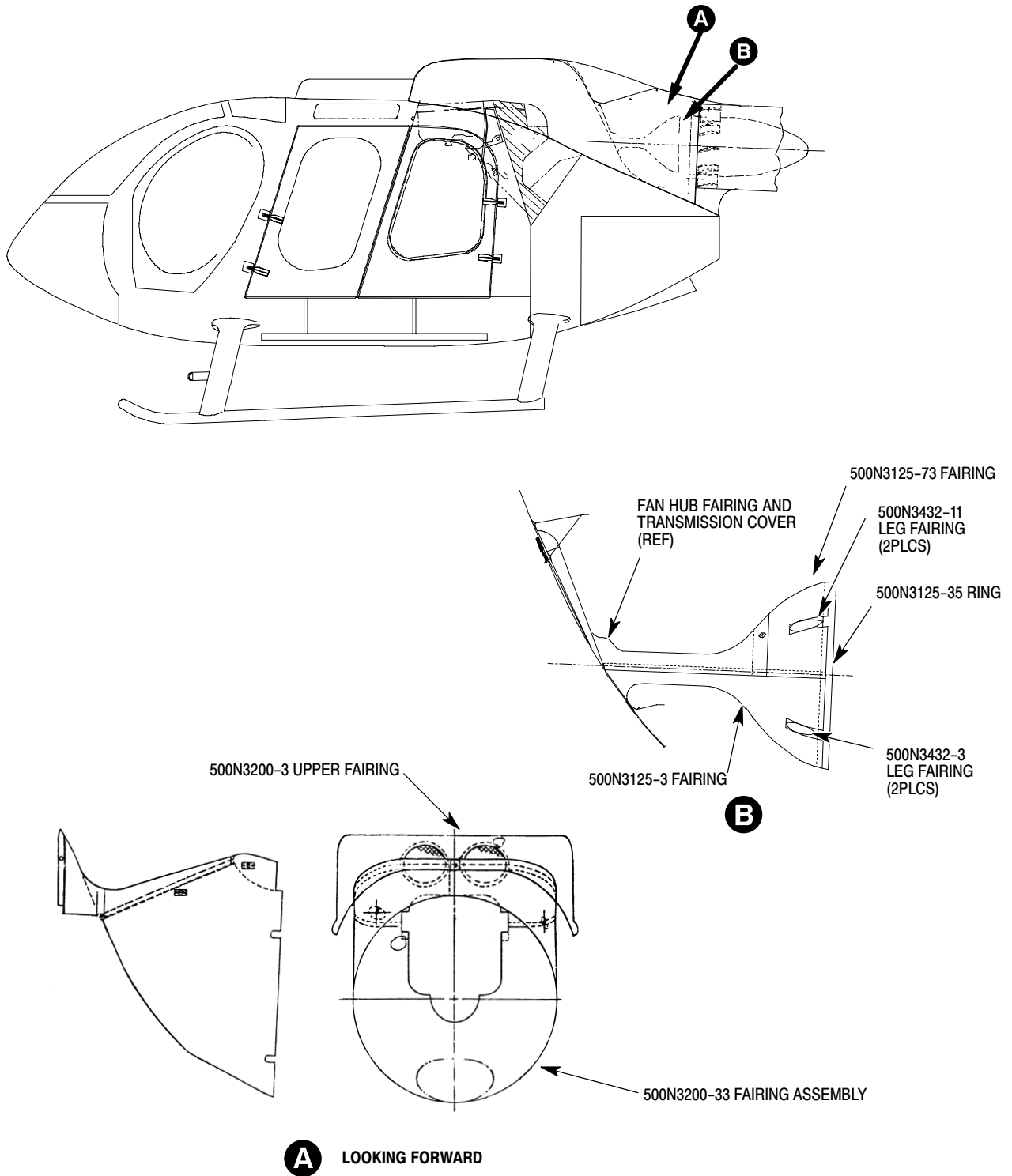

**Figure 1. Location of Fairings**

Copyright 1999-2010 by MD Helicopters Inc.

This document may be reproduced and distributed provided no fee is charged, the text is not modified, and this copyright notice is included.

DATE: 12 DECEMBER 2011  
PAGE 10 OF 28

# TECHNICAL BULLETIN

(Ref. Figure 2)

(7). Remove outer skin.

**NOTE:** Use standard sheet metal practices.



Inspect all retained parts and aft ring frame for cracks. Contact MDHI Field Service Dept. if any cracks are found.

- (a). Remove rivets and remove and retain outer ring frame upper skin (P/N 500N3426-3).
- (b). Remove rivets and remove and retain LH and RH upper cover (P/N 500N3426-13/-15).
- (c). Remove rivets and remove and retain LH angle (P/N 500N3426-11).
- (d). Remove rivets and remove and retain LH and RH strap (P/N 600N3000-7/-8).
- (e). Remove rivets and remove and retain LH and RH outer ring frame lower skin (P/N 500N3426-5/-6).
- (f). Remove rivets and remove and retain LH and RH outer aft fuselage skin (P/N 500N3127-3/-4).

## **B. Modification**

(Ref. Figure 2)

- (1). Remove and retain four nutplates from back of outboard facing flange of aft ring frame (Ref. Details D and E).
- (2). Remove upper and lower tailboom attach fittings.
  - (a). Remove rivets and remove and discard LH upper fitting (P/N 500N3422-3) and RH upper fitting (P/N 500N3422), LH bracket (P/N 500N3429-7), RH bracket (P/N 500N3429-6), nutplates, and clip (added by Service Bulletin SB600-036). Remove and retain LH bracket, (P/N 500N3428-5) and RH bracket, (P/N 500N3428-6). (Ref. Detail D.)
  - (b). Remove rivets and remove discard LH lower fitting (P/N 500N3422), RH lower fitting (P/N 500N3422-3) and nutplates. Remove and retain LH angle (P/N 500N3424-9, RH angle (P/N 500N3424-12, LH angle 500N3424-7), and RH angle (P/N 500N3424-8). (Ref. Detail E.)
- (3). If necessary, tag and de-pin wires from J208 and J513 (Ref. CSP-HMI-3, Section 96-00-00, Electrical Connectors).
- (4). Remove and retain hardware, clamp and guide tube (P/N 500N3210-1). (Ref. View B-B.)
- (5). Remove longerons and associated parts.
  - (a). Remove rivets and remove and discard LH doubler (P/N 600N3000-15, LH angle (P/N 500N3120-7), RH angle (P/N 500N3120-8), and spacers (LH and RH) (P/N 500N3120-35). (Ref. View B-B.)
  - (b). Remove rivets and remove and discard angles (P/N 500N3120-9, -10) and longerons (P/N 500N3120-3, -4). (Ref. View A-A.)

*Copyright 1999-2010 by MD Helicopters Inc.*

*This document may be reproduced and distributed provided no fee is charged, the text is not modified, and this copyright notice is included.*

# TECHNICAL BULLETIN

DATE: 12 DECEMBER 2011

PAGE 11 OF 28

- (6). Rework fan support.
  - (a). Trim both sides of fan support as shown. (Ref. Detail F.)
  - (b). Apply chemical coating to reworked areas per manufacturer's instructions.
  - (c). Apply primer to reworked areas per manufacturer's instructions.
- (7). Install new longerons (P/N 600N3120-1/-2) and angles (P/N 500N3120-9/-10).
  - (a). Position new longerons on airframe. (Ref. View A-A.)
  - (b). Temporarily install LH and RH outer aft fuselage skins (P/N 500N3127-3/-4) and match drill attach holes in longerons.
  - (c). Match drill nutplate attach holes in longerons.
  - (d). Remove LH and RH outer aft fuselage skins.

# TECHNICAL BULLETIN

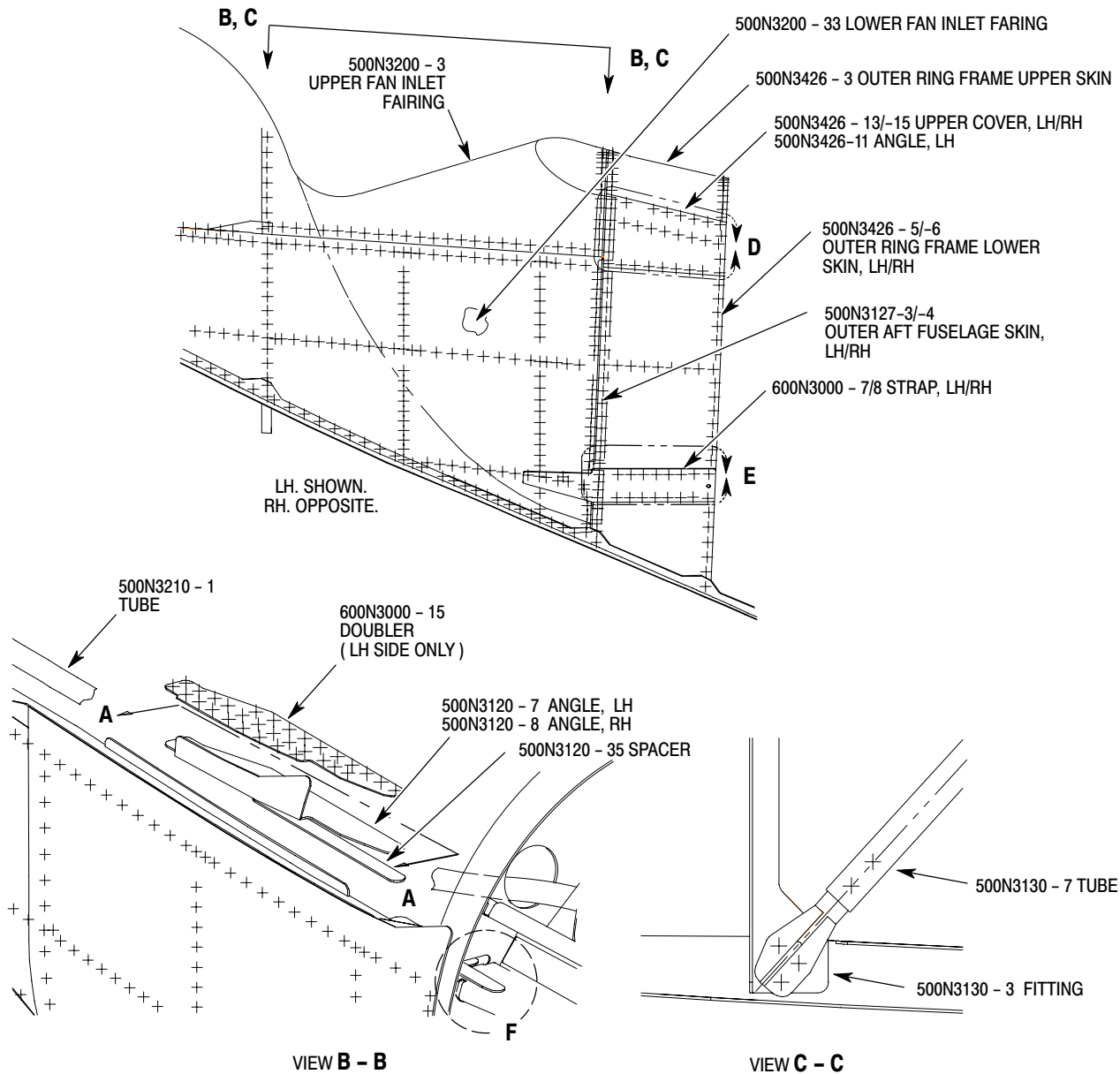
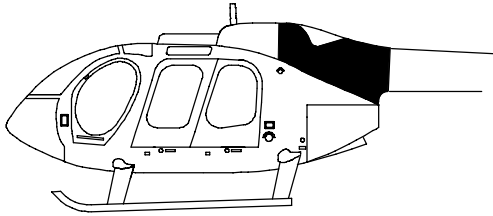

88-809-1

**Figure 2. Fuselage Aft Section Parts Removal and Modification (Sheet 1 of 2)**

*Copyright 1999-2010 by MD Helicopters Inc.  
 This document may be reproduced and distributed provided no fee is charged,  
 the text is not modified, and this copyright notice is included.*

# TECHNICAL BULLETIN

DATE: 12 DECEMBER 2011  
PAGE 13 OF 28

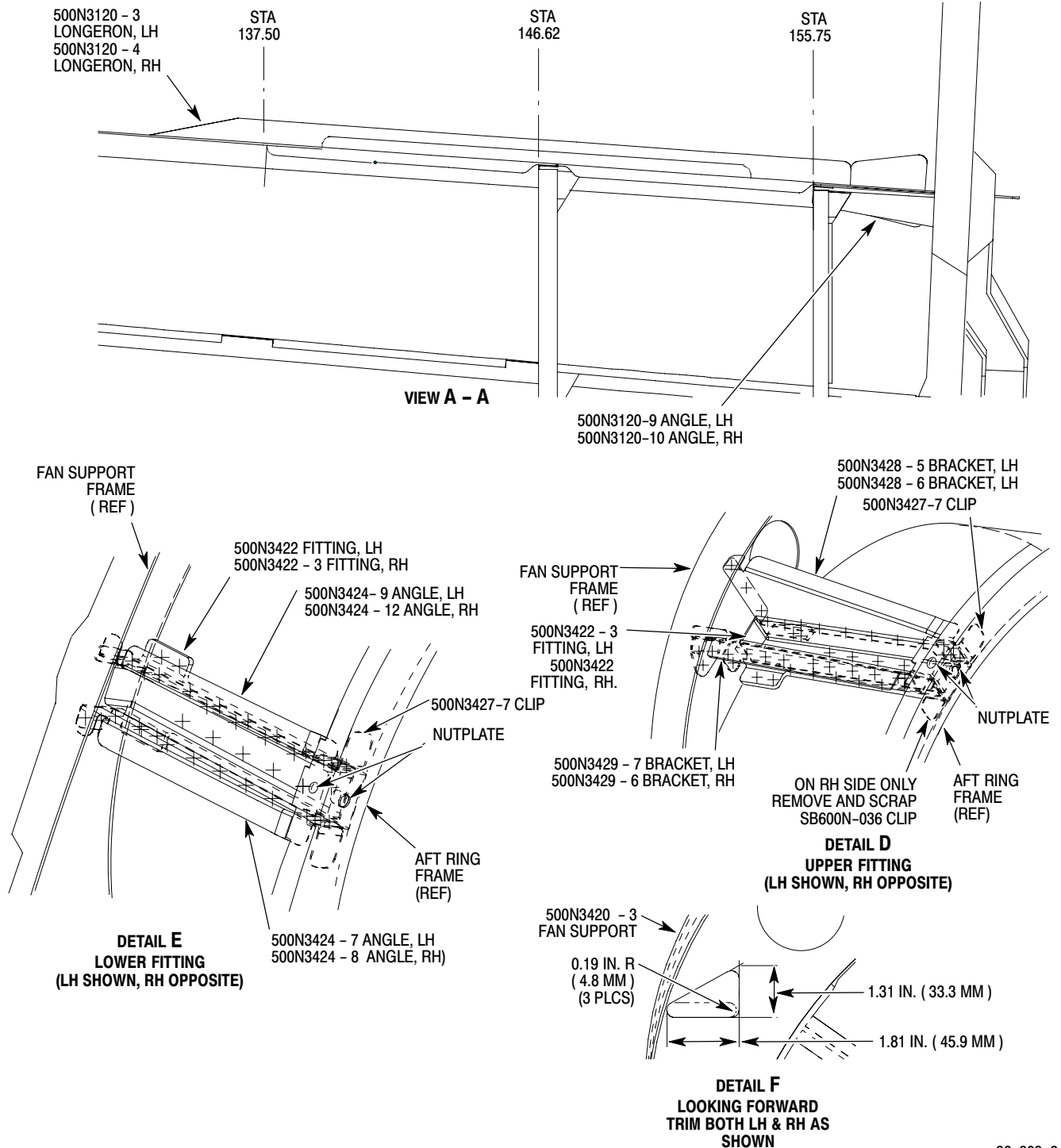

88-809-2

**Figure 2. Fuselage Aft Section Parts Removal and Modification (Sheet 2 of 2)**

Copyright 1999-2010 by MD Helicopters Inc.  
This document may be reproduced and distributed provided no fee is charged,  
the text is not modified, and this copyright notice is included.

# TECHNICAL BULLETIN

(Ref. Figure 3)

- (8). Position upper tailboom attach fittings. (Ref. View J-J.)
- Touch countersink and double flush install two MS20426A4-1 rivets in holes adjacent to each upper tailboom attach hole in aft ring frame.
  - Position new brackets (P/N 500N3429-9/-10), new fittings (P/N 600N3422-1) and retained brackets (P/N 500N3428-5/-6) between aft ring frame and fan support frame.
  - Position two upper clips (P/N 500N3427-7) and two lower clips (P/N 500N3427-9) and clamp into place.
  - Mark location for all rivet holes on brackets, fittings and clips.
  - Remove brackets, fitting and clips.



Ensure that minimum edge distance is maintained for all rivet holes.

- Drill rivet holes in new fitting using drill press.
- Deburr holes and remove all debris.
- Temporarily install clips, brackets and fittings with clecos.
- Match drill tailboom attach bolt hole in aft end of each fitting. (Ref. View L-L.)
- Remove brackets, fitting and clips.
- Deburr holes and remove all debris from fittings.
- Install clips, brackets and fittings with rivets, as shown. (Ref. View J-J.)



Check fit clearance between rivet tails and nutplate retainer before final installation. Buck rivets again, if needed, to provide clearance for nutplate retainer.

- Install nutplate (P/N MS21075L3) in fitting with rivets, as shown.
- (9). Position lower tailboom attach fittings. (Ref. View K-K.)
- Touch countersink and double flush install two MS20426A4-1 rivets in holes adjacent to each upper tailboom attach hole in aft ring frame.
  - Position new fittings (P/N 600N3422-1) and retained angles (P/N 500N3424-7/-8/-9/-12) between aft ring frame and fan support frame.
  - Position two upper clips (P/N 500N3427-7) and two lower clips (P/N 500N3427-7) and clamp into place.
  - Mark location for all rivet holes on brackets, fittings and clips.
  - Remove brackets, fitting and clips.



Ensure that minimum edge distance is maintained for all rivet holes.

- Drill rivet holes in new fitting using drill press.

# TECHNICAL BULLETIN

DATE: 12 DECEMBER 2011

PAGE 15 OF 28

- (g). Deburr holes and remove all debris.
- (h). Temporarily install clips, brackets and fittings with clecos.
- (i). Match drill tailboom attach bolt hole in aft end of each fitting. (Ref. View L-L.)
- (j). Remove brackets, fitting and clips.
- (k). Deburr holes and remove all debris from fittings.
- (l). Install clips, brackets and fittings with rivets, as shown. (Ref. View K-K.)



Check fit clearance between rivet tails and nutplate retainer before final installation. Buck rivets again, if needed, to provide clearance for nutplate retainer.

- (m). Install nutplate (P/N MS21075L3) in fitting with rivets, as shown.
- (10). Install angles and spacers.
  - (a). Layout rivet hole pattern on longerons and drill pilot holes using #40 drill bit. (Ref. View F-F.)
  - (b). Position aft section angles (P/N 600N3121-1/-2), spacers (P/N 600N3122-3), angles (P/N 600N3123-1/-2) and angles (P/N 600N3124-1/-2) in position on longeron as shown and clamp securely into place. (Ref. Section H-H.)

## NOTE:

- Maintain 0.010-0.025 inch (0.254-0.635mm) gap between longeron and spacer (P/N 600N3122-3).
- Shim as required with 2024-T3 aluminum sheet to eliminate gap between spacers (P/N 600N3122-3) and brackets (P/N 500N3429-9/-10).
- Fabricate 0.063 inch (1.60 mm) shim for specific rivet location as shown. (Ref. View F-F.)
  - (c). Transfer holes to all angles and spacers.
  - (d). Drill and cleco rivet holes through angles and spacers. (Ref. View F-F.)
  - (e). Remove angles and spacers and deburr rivet holes. Touch up with primer as needed.
  - (f). Install longerons in airframe and install nutplates on longerons.
  - (g). Match drill and temporarily install angles (P/N 500N3120-9/-10).
  - (h). Install angles and spacers on longerons and attach with rivets, as shown. (Ref. View F-F.)
  - (i). Permanently install LH and RH outer aft fuselage skins (P/N 500N3127-3/-4).



When cold-working the rivet holes, ensure holes do not get oversized. Ream to proper size as per Notes 1 and 2 of Figure 3.

- (j). Cold work 12 rivet holes (each side) using proper sized tooling.
- (k). Install 12 rivets (Ref. Sheet 2 of 5)
- (11). Using drill fixture 600N3510-1-DJ1, enlarge four tailboom attach holes in aft ring frame. (Ref. View L-L.)

# TECHNICAL BULLETIN

- (a). Install one nutplate retainer (P/N FTR-771-603-.280-S) in hole in aft end of each fitting using nutplate retainer tooling per manufacturer's instructions. Ensure that flat side of nutplate retainer is facing toward fitting so that nutplate can be installed.
- (b). Install one nutplate (P/N NAS1794C6) in each retainer using clip supplied with retainer.
- (12). Reinstall four nutplates (P/N MS21075L3) with rivets (P/N MS20605R3W2) on back of outboard facing flange of aft ring frame. (Ref. Figure 3, Main View.)
- (13). Install guide tube, as follows. (Ref. Section G-G.)
  - (a). Place guide tube (P/N 500N3210-1) into position.
  - (b). Route tube (P/N 500N3000-51) with guide tube.
  - (c). Place clamp on guide tube and secure with one bolt, washer and spacer.
  - (d). Secure tube to guide tube with four ty-wraps, as shown.
- (14). If required, reconnect wires to connectors J208 and J513 (Ref. CSP-HMI-3, Section 96-00-00, Electrical Connectors).

# TECHNICAL BULLETIN

DATE: 12 DECEMBER 2011

PAGE 17 OF 28

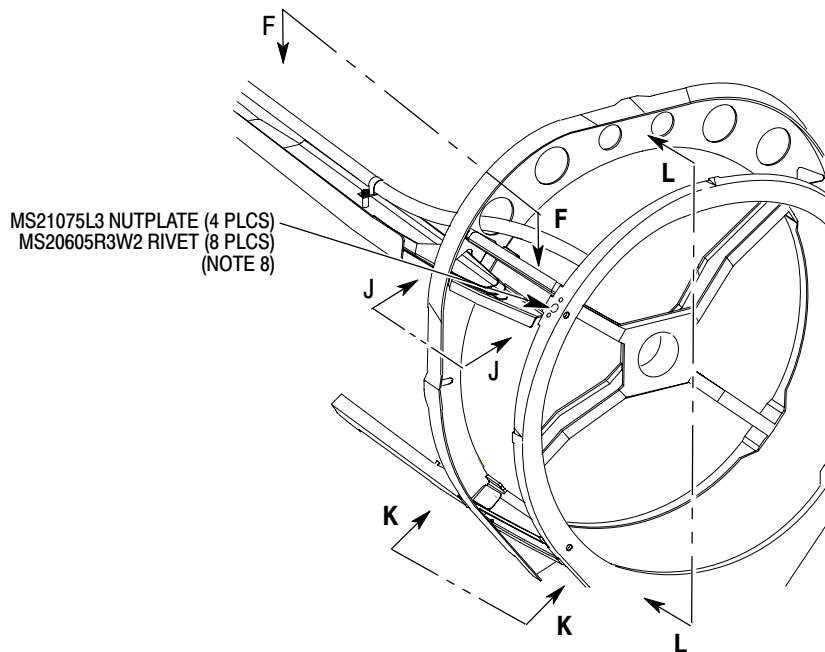
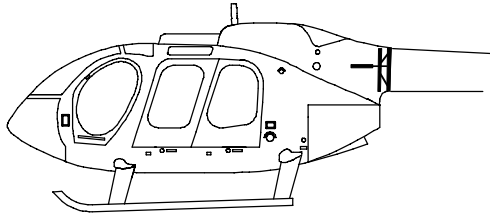

**NOTES:**

1. COLD WORK RIVET HOLES USING 4 - 0 - N SIZED TOOLING AND CBS-4-0-N SLEEVES. REAM TO 0.128 IN. ( 3.25 MM ) AFTER COLD WORK.
2. COLD WORK RIVET HOLES USING 4 - 2 - N SIZED TOOLING AND CBS-4-2-N SLEEVES. REAM TO 0.159 IN. ( 4.04 MM ) AFTER COLD WORK.
3. TRIM FITTING FOR RH. INSTALLATION AS REQUIRED TO CLEAR STRUCTURE. BLEND TRANSITIONS AND RADIUS ALL CORNERS. FINISH WITH CHEMICAL COATING AND PRIMER.
4. TRIM TO MAINTAIN 0.010 - 0.025 IN. ( 0.254 - 0.635 MM ) GAP BETWEEN 600N3120 - 1 / -2 LONGERON AND 600N3122 - 3 SPACER (REF. VIEW N)
5. SHIM AS REQUIRED WITH 2024 - T3 AL SHEET TO ELIMINATE GAP BETWEEN 600N3122 SPACER AND 500N3429 BRACKET. FABRICATE SHIM TO SPAN FROM FORWARD PIN RIVETS AND AFT TO LAST RIVET ON 600N3122 SPACER. WIDTH TO MATCH SPACER.
6. FABRICATE 0.063 IN. ( 1.60 MM ) SHIM FOR THIS RIVET LOCATION.
7. MATCH DRILL TO 600N3422 FITTING. INSTALL NUTPLATE RETAINER IN 600N3422 FITTING PER MANUFACTURERS INSTRUCTIONS PER DIMENSIONS SHOWN USING NUTPLATE RETAINER INSTALLATION TOOLING.
8. REMOVE AND RETAIN FOUR NUTPLATES. REINSTALL NUTPLATES WITH MS20605R3W2 RIVETS AFTER INSTALLATION OF TAILBOOM ATTACH BOLT NUTPLATES.
9. MHS5583-5 COLLARS MAY BE SUBSTITUTED FOR MHS5582-5 COLLARS IF THERE IS NO MISALIGNMENT AND SHORT THREAD PROTRUSION.

88-810-1A

**Figure 3. Fuselage Aft Section Modification (Sheet 1 of 5)**

Copyright 1999-2010 by MD Helicopters Inc.

This document may be reproduced and distributed provided no fee is charged, the text is not modified, and this copyright notice is included.

DATE: 12 DECEMBER 2011  
 PAGE 18 OF 28

# TECHNICAL BULLETIN

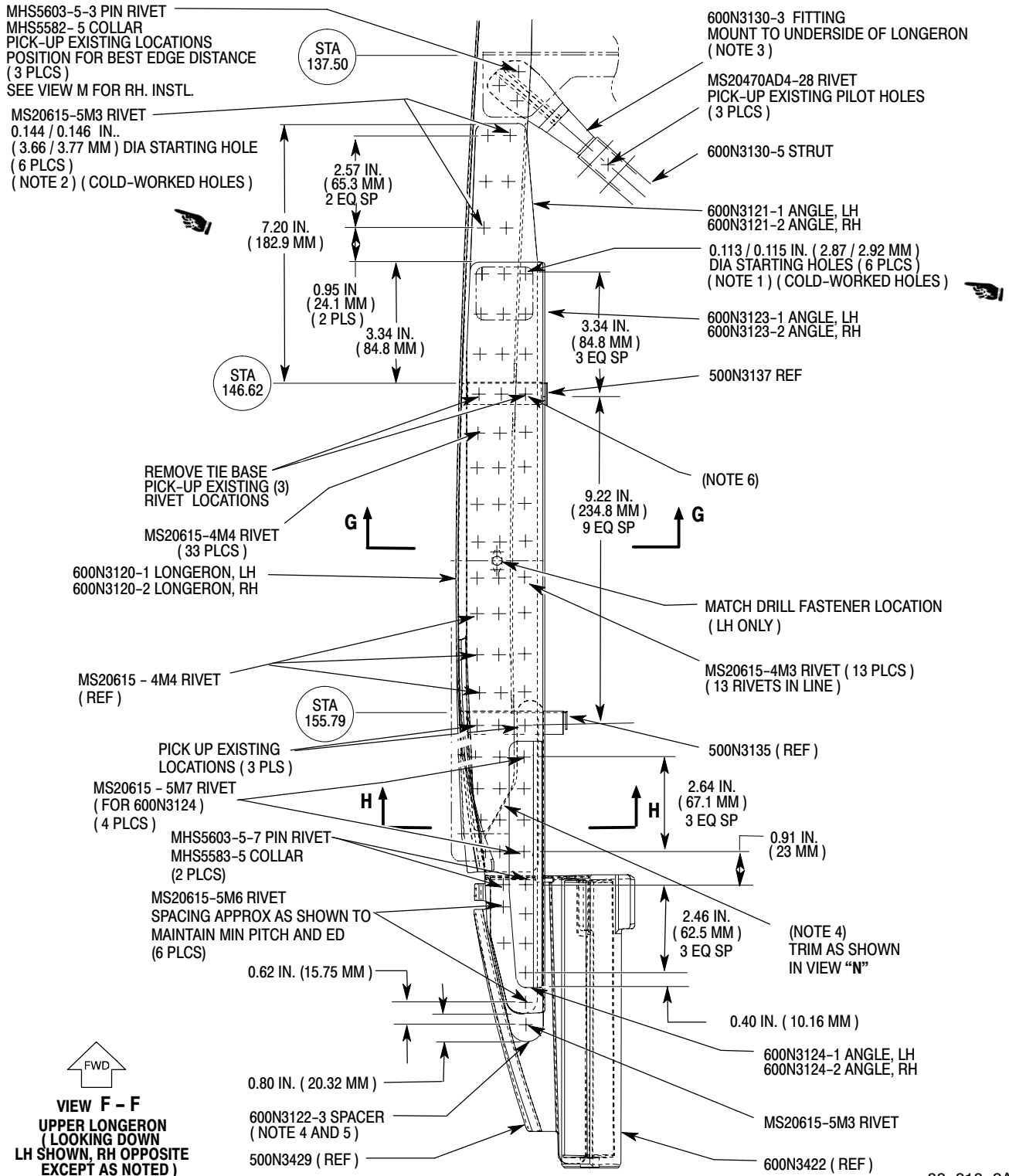

88-810-2A

**Figure 3. Fuselage Aft Section Modification (Sheet 2 of 5)**

Copyright 1999-2010 by MD Helicopters Inc.  
 This document may be reproduced and distributed provided no fee is charged,  
 the text is not modified, and this copyright notice is included.

# TECHNICAL BULLETIN

DATE: 12 DECEMBER 2011  
PAGE 19 OF 28

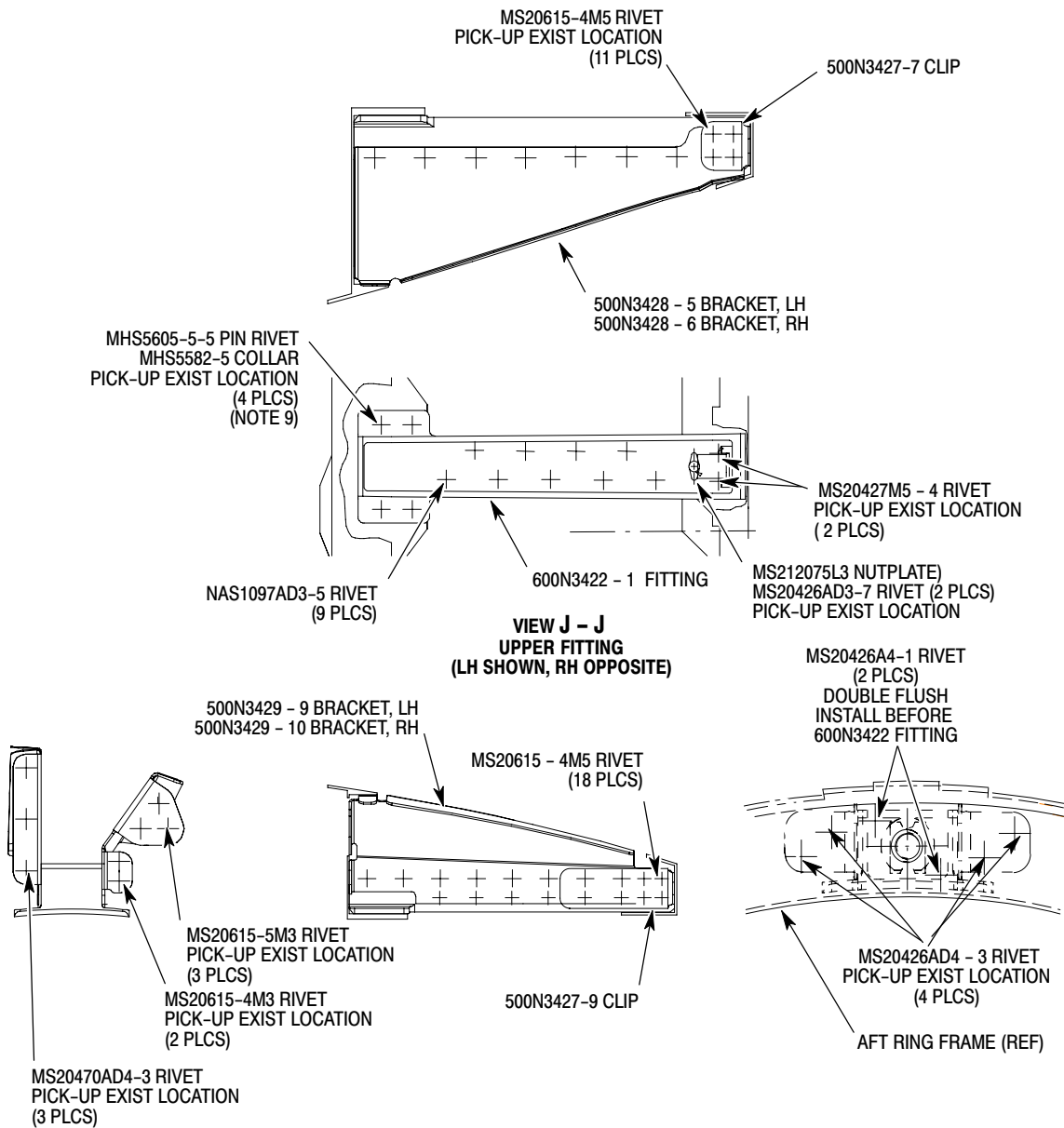
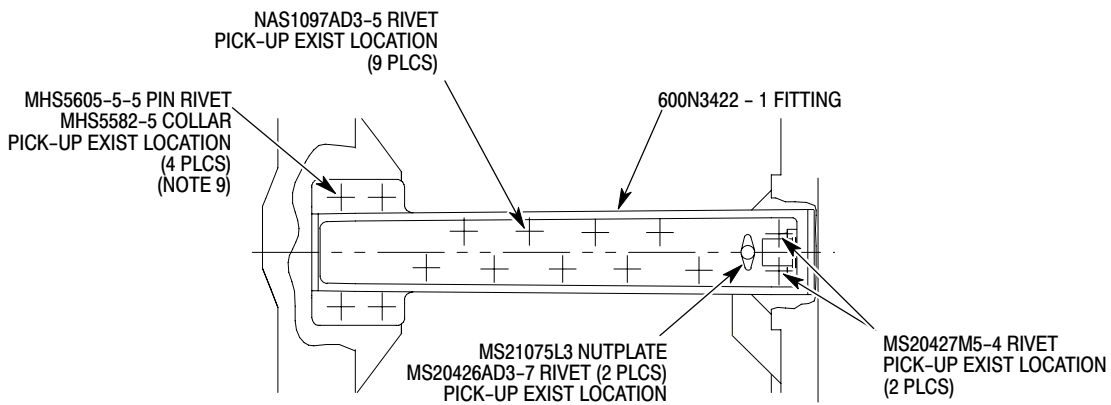
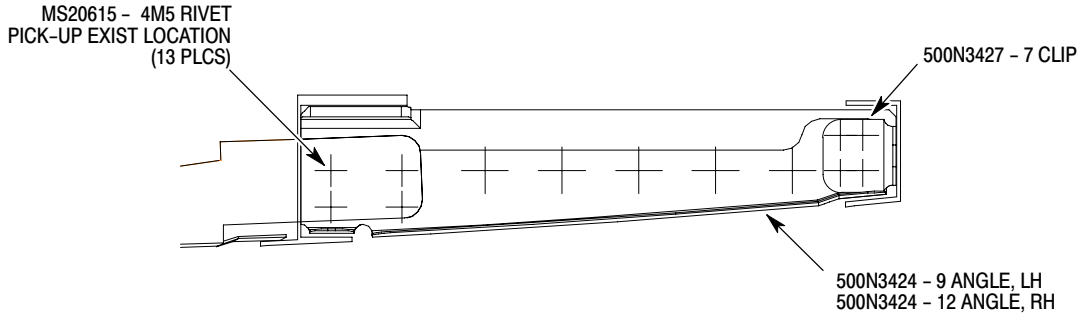

**Figure 3. Fuselage Aft Section Modification (Sheet 3 of 5)**

Copyright 1999-2010 by MD Helicopters Inc.  
This document may be reproduced and distributed provided no fee is charged,  
the text is not modified, and this copyright notice is included.

DATE: 12 DECEMBER 2011  
 PAGE 20 OF 28

# TECHNICAL BULLETIN



**VIEW K - K  
 LOWER FITTING  
 (LH SHOWN, RH OPPOSITE)**

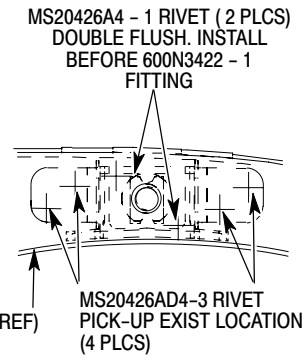
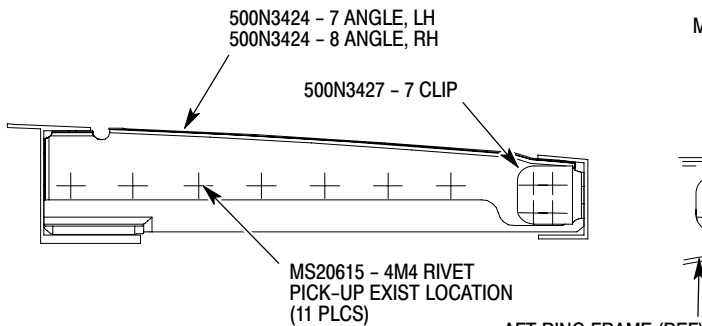
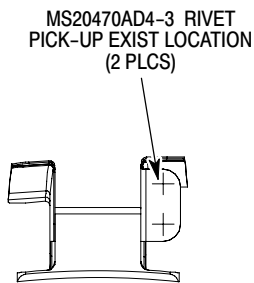

88-810-4

**Figure 3. Fuselage Aft Section Modification (Sheet 4 of 5)**

Copyright 1999-2010 by MD Helicopters Inc.  
 This document may be reproduced and distributed provided no fee is charged,  
 the text is not modified, and this copyright notice is included.

# TECHNICAL BULLETIN

DATE: 12 DECEMBER 2011  
PAGE 21 OF 28

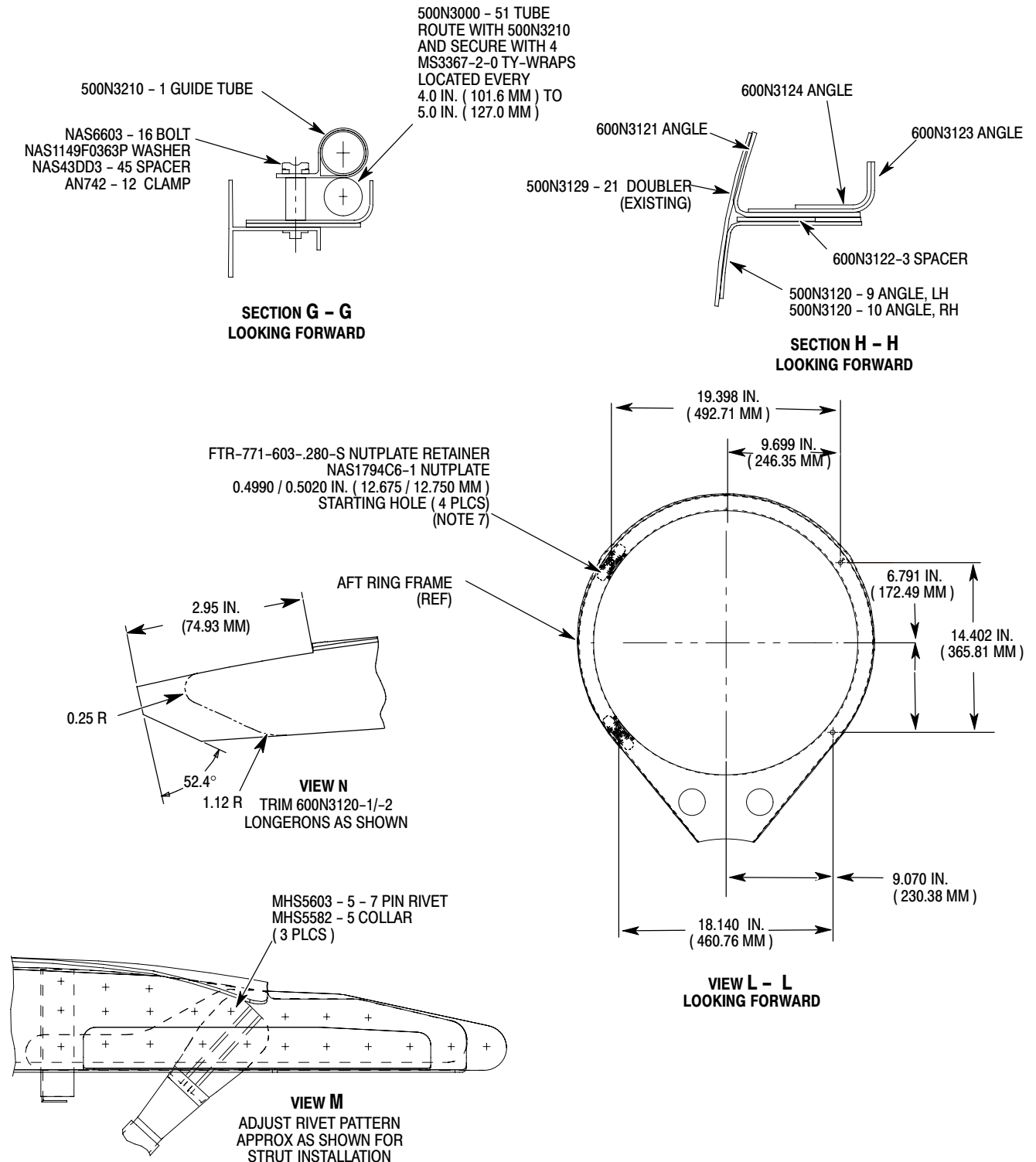

88-810-5A

**Figure 3. Fuselage Aft Section Modification (Sheet 5 of 5)**

Copyright 1999-2010 by MD Helicopters Inc.

This document may be reproduced and distributed provided no fee is charged,  
the text is not modified, and this copyright notice is included.

DATE: 12 DECEMBER 2011  
PAGE 22 OF 28

# TECHNICAL BULLETIN

(Ref. Figure 4)

- (15). Install inspection hole.
  - (a). Locate and drill one 0.50 inch (12.7mm) inspection hole (L137) in left side of fuselage.
  - (b). Apply chemical coating and primer to inspection hole per manufacturer's instructions.
  - (c). Install doubler with six MS20470AD3 rivets.

**NOTE:** Seal exterior sheet metal parts with sealing compound per manufacturer's instructions.

## **C. Completion**

- (1). Install outer skin.
  - (a). Install LH angle (P/N 500N3426-11) on ring frame.
  - (b). Install LH and RH outer ring frame lower skin (P/N 500N3426-5/-6).
  - (c). Install LH and RH strap (P/N 600N3000-7/-8).
  - (d). Install LH and RH upper cover (P/N 500N3426-13/-15).
  - (e). Install upper outer ring frame skin (P/N 500N3426-3) using NAS1919B04S rivets.
- (2). Position fairing assembly (P/N 500N3200-33) in fuselage and bond bottom and sides to fuselage skin and stringers using epoxy adhesive (EA9309.3). (Ref. Figure 1.)
- (3). Install strut assembly. (Ref. Figure 3, View F-F.)
  - (a). Temporarily assemble strut (P/N 600N3130-5 and two fittings (P/N 600N3130-3).
  - (b). Place strut assembly as shown and clamp into position.
  - (c). Back drill rivet holes in fitting (through longerons and strut).
  - (d). Remove strut and fittings and deburr rivet holes.
  - (e). Place fittings on strut and attach with rivets.
  - (f). Position strut assembly and attach with rivets, as shown.
- (4). Install anti-torque fan liner (Ref. CSP-HMI-2, Section 64-25-30, Anti-Torque Fan Liner (Felt Metal Seal) Installation).
- (5). Install fairings.
  - (a). Attach fairing assembly (P/N 500N3200-33) to fan support frame using NAS1738B4-6 rivets .
  - (b). Position upper fairing (P/N 500N3200-3) on fuselage. (Ref. Figure 1.)
  - (c). Bond upper fairing and fairing assembly using epoxy adhesive (EA9309.3) per manufacturer's instructions.
  - (d). Attach upper fairing (P/N 500N3200-3 to longerons and fan support frame using NAS1720KE4L2A rivets .

# TECHNICAL BULLETIN

DATE: 12 DECEMBER 2011

PAGE 23 OF 28

- (e). If necessary, position ring (P/N 500N3125-35) and fairing (P/N 500N3125-3) at the fan support.
- (f). Bond ring, fairing and leg fairings (P/N 500N3432-3, -11) to fan support using epoxy adhesive (EA9330.3) per manufacturers instructions.
- (g). Bond forward lower end of fairing (P/N 500N3125-3) to upper fairing (P/N 500N3200-3) and fairing assembly (P/N 500N3200-33) using epoxy adhesive (EA9330.3) per manufacturers instructions.

# TECHNICAL BULLETIN

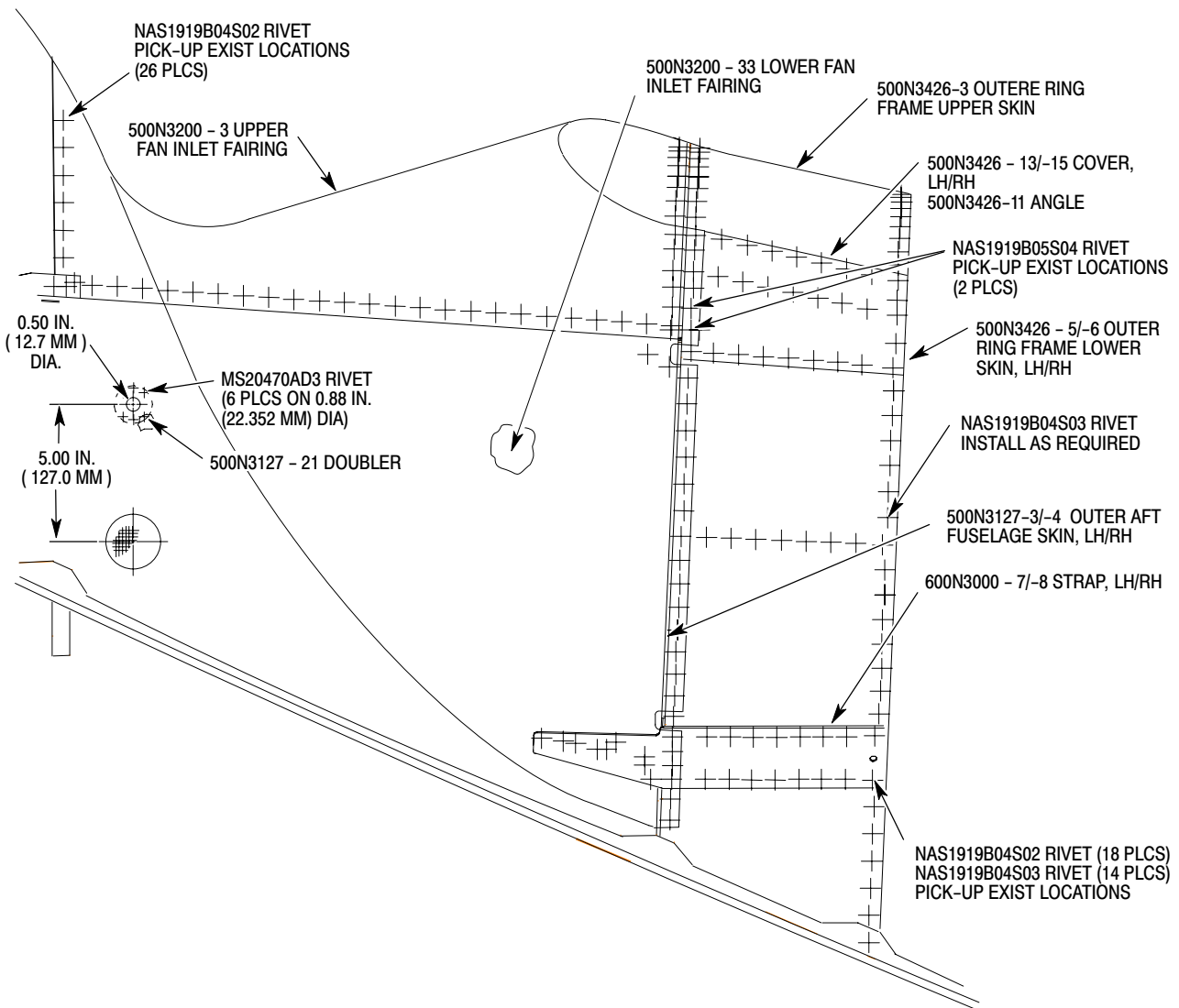
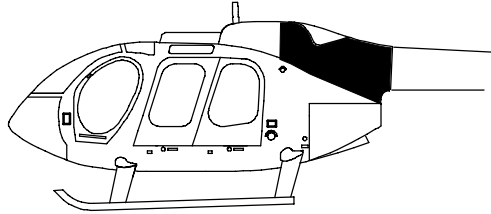

**Figure 4. Fuselage Aft Section Rework and Installation of Parts**

Copyright 1999-2010 by MD Helicopters Inc.  
 This document may be reproduced and distributed provided no fee is charged,  
 the text is not modified, and this copyright notice is included.

# TECHNICAL BULLETIN

DATE: 12 DECEMBER 2011

PAGE 25 OF 28

(Ref. Figure 5)

(6). Modify tailboom assembly

**NOTE:** After completing the modification procedure below, the tailboom assembly cannot be installed on any helicopter serial RN003 thru RN068 that has not been modified by this Bulletin.

- (a). Using drill fixture 600N3510-1-DJ1, ream two tailboom attach holes to 0.378/0.386 inch (9.60/9.80 mm) and spotface to 0.750 inch (19.05 mm) diameter and 0.06 inch (1.5 mm) maximum depth.
- (b). Apply chemical coating to reworked holes in radius blocks per manufacturer's instructions.
- (c). Reidentify modified tailboom assembly. Pre and post modification part numbers are shown in Table 1).
  - 1). Carefully remove ID plate from tailboom assembly.
  - 2). Clean area where new ID plate will be installed with isopropyl alcohol or acetone.
  - 3). Peel backing off new ID plate and press plate on prepared surface. Roll ID plate with 1 inch (25.4 mm) cylindrical plastic roller.
  - 4). Edge seal ID plate with clear epoxy.

**Table 1. Tailboom Assembly Reidentification**

PRE MODIFICATION TAILBOOM P/N	POST MODIFICATION TAILBOOM P/N
600N3500-503	600N3500-513
600N3500-505	600N3500-515
600N3500-507	600N3500-517
600N3500-509	600N3500-511

- (7). Install fan inter-connect drive shaft (Ref. CSP-HMI-2, Section 63-15-30, Fan Inter-Connect Drive Shaft Installation).
- (8). Install fan hub fairing and transmission cover (Ref. CSP-HMI-2, Section 53-30-30, Fan Hub Fairing and Transmission Cover Installation).
- (9). Install engine plenum access cover (Ref. CSP-HMI-2, Section 53-30-30, Engine Plenum Access Cover Installation).
- (10). Install fan air inlet screen (Ref. CSP-HMI-2, Section 53-30-30, Fan Air Inlet Screen Installation)
- (11). Refer to Basic Handbook of Maintenance Instructions (CSP-HMI-2), Section 05-00-00 for recurring inspection requirements.

# TECHNICAL BULLETIN

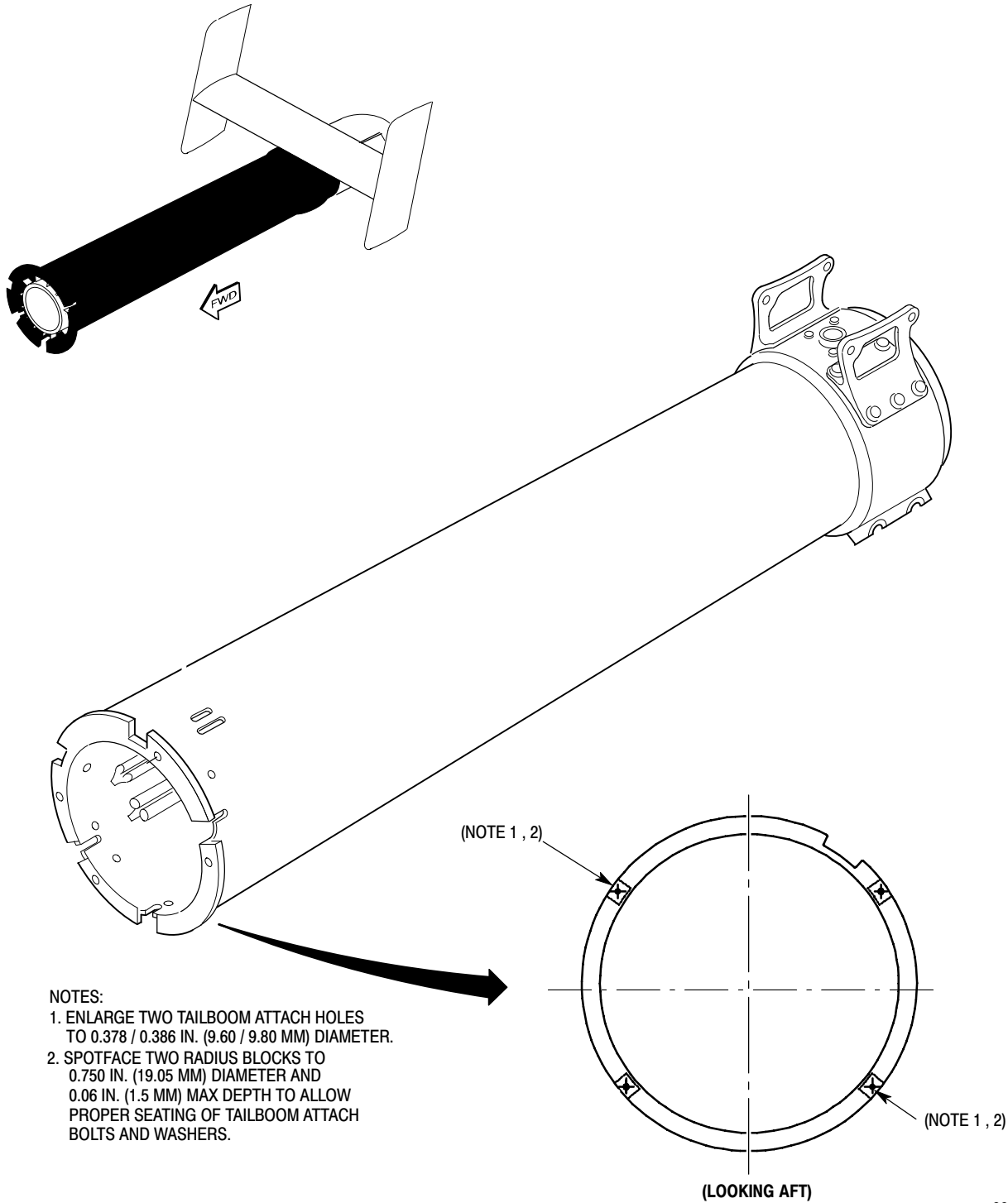

**NOTES:**

1. ENLARGE TWO TAILBOOM ATTACH HOLES TO 0.378 / 0.386 IN. (9.60 / 9.80 MM) DIAMETER.
2. SPOTFACE TWO RADIUS BLOCKS TO 0.750 IN. (19.05 MM) DIAMETER AND 0.06 IN. (1.5 MM) MAX DEPTH TO ALLOW PROPER SEATING OF TAILBOOM ATTACH BOLTS AND WASHERS.

**Figure 5. Tailboom Assembly Rework**

*Copyright 1999-2010 by MD Helicopters Inc.*

*This document may be reproduced and distributed provided no fee is charged, the text is not modified, and this copyright notice is included.*



# TECHNICAL BULLETIN

DATE: 12 DECEMBER 2011

PAGE 27 OF 28

### **3. IDENTIFICATION**

Identify reworked tailboom assembly in accordance with the Accomplishment Instructions of the Bulletin.

### **4. DISPOSITION OF PARTS REMOVED**

Scrap

### **5. COMPLIANCE RECORD**

Record Compliance with this Technical Bulletin in the Compliance Record section of the helicopter Log Book.

Fax the Bulletin Incorporation Form to MDHI Field Service at DATAFAX: (480) 346-6813.

