



TECHNICAL BULLETIN

DATE: 21 APRIL 1981
PAGE 1 OF 9

INSTALLATION OF ENGINE AIR INLET DEFLECTOR KIT, PN M30287-501

1. PLANNING INFORMATION

A. MODELS AFFECTED:

All 500 Model 369H Series Helicopters

B. PREFACE:

This Service Information Notice provides procedures for installing an engine inlet foreign particle diverter to the engine air induction system. The purpose of this kit is to reduce the ingestion of large dust and sand particles as well as heavy, wet snow that can cling to the aircraft and then break free.

C. TIME OF COMPLIANCE:

At owners and operators discretion

D. FAA APPROVAL:

FAA/DER APPROVED 4 May 1981

E. WEIGHT AND BALANCE DATA:

Weight (pounds)	Longitudinal Arm (inches)	Longitudinal Moment (in.-lb/100)
1.57	80.9	1.27

F. REFERENCE:

500 Model 369H Series Basic HMI; Issued 1 October 1972, Revision No. 8, 1 December 1980

DATE: 21 APRIL 1981
PAGE 2 OF 9

TECHNICAL BULLETIN

G. PARTS LIST:

REPLACEMENT PARTS/SUPPLIES			
Nomenclature	Part No.	Qty.	Source
Engine air inlet deflector kit	M30287-501	1	HH

H. MATERIALS:

MATERIALS			
Nomenclature	Part No.	Qty.	Source
Aliphatic naphtha, type II (TT-N-95)		AR	Chevron U.S.A. Shell Oil Co.
Masking tape, clear	670 (or equiv.)	AR	Minnesota Mining and Mfg. Industrial Tape Div., 3M Center St. Paul, MN 55101
Cellophane sheeting		AR	Commercial
Cement	PS-18 or PS-30	AR	Cadillac Plastic-Chemical Co. 1801 W. Edgar Rd. Linden, NJ 07036
	Weld-on-28 or Weld-on-40	AR	Industrial Polychemical Service 17109 S. Main St. Gardena, CA 90247
Primer coating, zinc chromate, low-moisture-sensitive (TT-P-1757)	908-L-02110	AR	Glidden-Durkee Div., SCM 900 Union Commerce Bldg. Cleveland, OH 44115
	1063-166	AR	E.I. DuPont de Nemours Co. Marshall Laboratory 3500 Grays Ferry Ave. Philadelphia, PA 19146
Acrylic lacquer (MIL-L-81352)	HMS 15-1083 (specify color)	AR	Sherwin Williams Co. 6930 Telegraph Road City of Commerce, CA 90040
	HMS 15-1083 (specify color)	AR	Sterling Lacquer Mfg. Co 3150 Brannon Ave. St. Louis, MO 63139



TECHNICAL BULLETIN

DATE: 21 APRIL 1981

PAGE 3 OF 9

I. TOOLS AND EQUIPMENT:

TOOLS AND EQUIPMENT			
Nomenclature	Part No.	Qty.	Source
Straight edge, 12-inch		1	Commercial
Wedglock fasteners	AT550M AT553M (or equiv.)	46 5	Wedglock Division, Monogram Industries, Inc. 1001 Monterey Pass Rd. Monterey Park, CA 91754
Pliers	200 (or equiv.)	1	Wedglock
Center punch		1	Commercial
Drill motor, 1/4-inch, portable		1	Commercial
Drill bits: 1/16 inch No. 40 (0.098 inch) No. 30 (0.128 inch) No. 25 (0.1495 inch) No. 9 (0.1960 inch) No. 7 (0.2010 inch)		AR	Commercial
Hand riveter	350 (or equiv.)	1	Cherry Fasteners, Townsend Div., Textron Inc., 1224 E. Warner Ave., Santa Ana, CA 92707
Nose assy	35004	1	Cherry Fasteners
Rivet gun		1	Commercial
Bucking bar		1	Commercial
No. 10 hole finder	AT 500-55 or AT 532-65	1	ATI Industries, Inc. 220 N. Tulip St. Escondido, CA 92025

TECHNICAL BULLETIN

2. REWORK PROCEDURE

- a. Trim and affix canopy upper windshield stiffeners as follows (see Figure 1):
 1. Trim 0.75 inch from outboard end of each stiffener. Use hacksaw or power saw as availability permits.
 2. Remove rough edges with suitable sandpaper, then remove all sawdust.

WARNING

Naphtha is extremely flammable. Do not permit smoking inside helicopter when working with naphtha. Have naphtha on hand in small quantities only. If naphtha is spilled, wipe it dry immediately; open doors on both sides of helicopter, if possible, to allow for rapid drying and dilution of fumes.

3. Wash stiffeners and inner surfaces of left and right upper windshields carefully with naphtha. Use soft cloth or industrial wiping tissues only.
 4. Apply clear masking tape to inner surface of each windshield to delineate area to receive stiffener.
 5. Completely cover windshields beyond taped area with cellophane sheets. Hold sheets in place with masking tape. Cement must not be allowed to seep under edges of tape or otherwise attack acrylic windshield where solvent action is not desired.
 6. Prepare cement as specified by manufacturer.
 7. Apply a thin film of mixed cement to windshields and stiffeners, then join stiffeners to windshields immediately.
 8. Apply light pressure to stiffeners to press out air bubbles, remove excess cement by scraping it away, then secure stiffeners in position with sufficient masking tape to maintain pressure.
 9. Allow cement to cure at least 2 hours before removing masking tape from stiffeners.
- b. Remove 8 screws and washers securing tail rotor shaft access door to right fairing and aft section fairing, and remove door. Retain door for reuse.
 - c. Remove 32 screws and washers securing original left and right engine inlet fairing assemblies, and remove fairing assemblies.
 - d. Remove original left and right lower vanes, and replace them with new, reinforced, lower vane assemblies.
 - e. Set new left and right fairings in correct installed position, then install fasteners in front, top, and inside to hold fairing halves together. (See Figure 3.)
 - f. Set new left and right flange assemblies in place, and secure them to fuselage and against fairings with masking tape to simulate proper installation position.
 - g. Insert 1/16-inch drill bit into front pilot holes in left and right flanges, and drill pilot holes in fairings.
 - h. Install black, 1/16-inch Wedglock (or similar) fasteners in holes, readjust flanges to proper position as required, then drill through remaining pilot holes, each side. Install fasteners in approximately every other pilot hole.



TECHNICAL BULLETIN

DATE: 21 APRIL 1981

PAGE 5 OF 9

i. Remove fairings from helicopter, and enlarge pilot holes in fairings to 0.128 inch for 1/8-inch rivets. Use No. 30 drill.

j. Install NAS1398B4-2 rivets with Cherry 350 gun and 35004 nose assembly, or equivalent.

NOTE: Before installing rivets, deburr holes as required, and coat holes in aluminum flanges with zinc chromate primer. Install rivets while coating is wet.

k. Reinstall left and right fairing assemblies, and secure each with screws as before.

NOTE: Before drilling pilot holes in flanges, remove interior paneling from ceiling so frequent checks of accuracy can be made. Cover lower interior of helicopter with drop cloth to catch metal chips.

l. Using a No. 10 hole finder, locate and drill holes, using a No. 7 (0.2010 inch) drill, in new left and right flange assemblies. Deburr holes as required.

m. Remove fairing assemblies from helicopter, and install plate nuts on right fairing assembly for access door. (See Figure 4.)

n. Apply two top coats of acrylic lacquer to match original pattern.

o. Reinstall fairing assemblies. Apply zinc chromate primer inside clearance holes in flanges and on screw threads. Install screws while primer is wet.

p. Remove drop cloth, and vacuum clean interior of helicopter.

q. Reinstall ceiling paneling.

r. Record compliance with this Service Information Notice in Compliance Record of Helicopter Log Book.

TECHNICAL BULLETIN

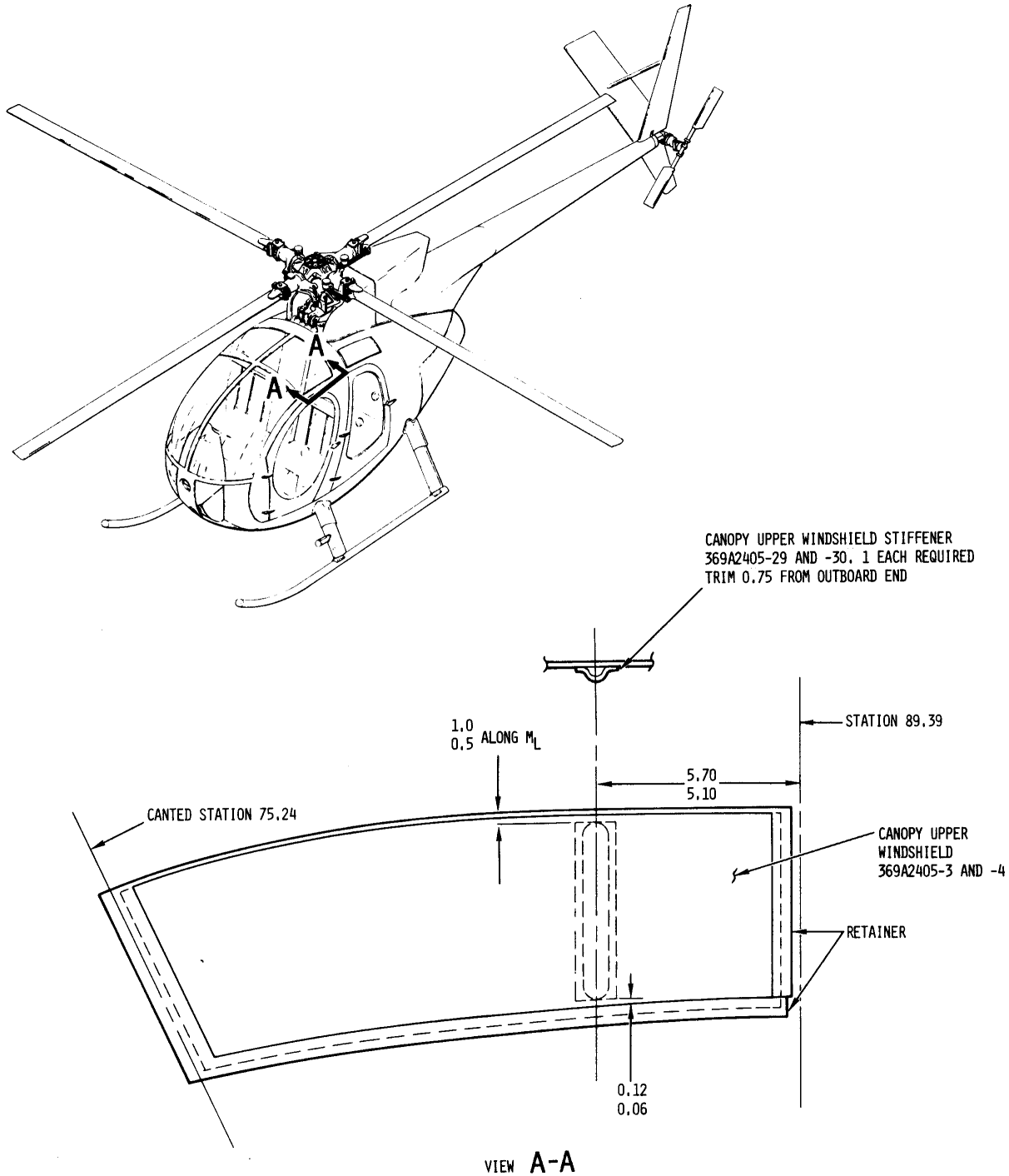
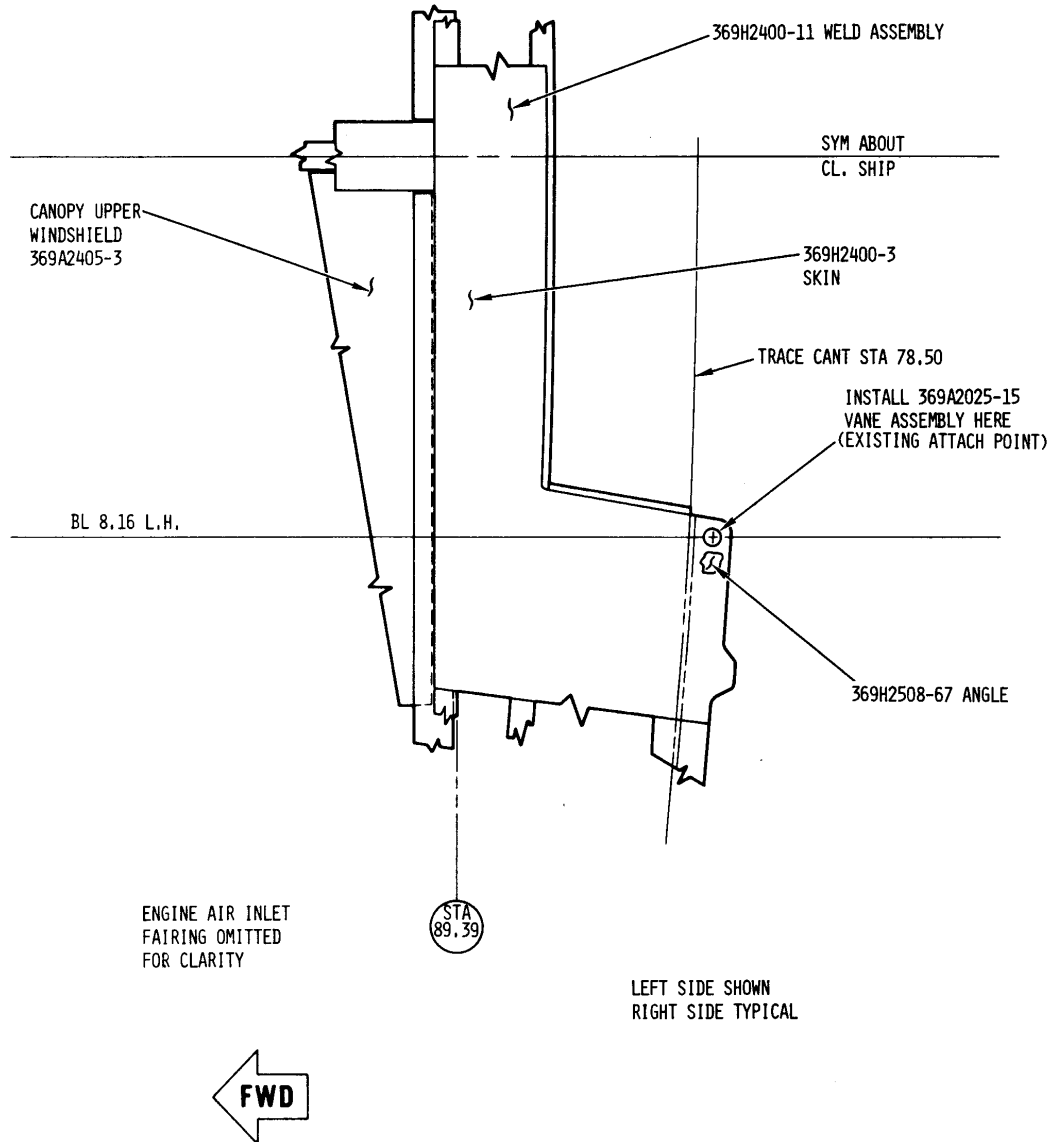

Figure 1. Canopy Upper Windshield Stiffener Bonding Details

TECHNICAL BULLETIN

DATE: 21 APRIL 1981
PAGE 7 OF 9



88-474

Figure 2. Left and Right Lower Vane Assembly Mounting Hole Locations

TECHNICAL BULLETIN

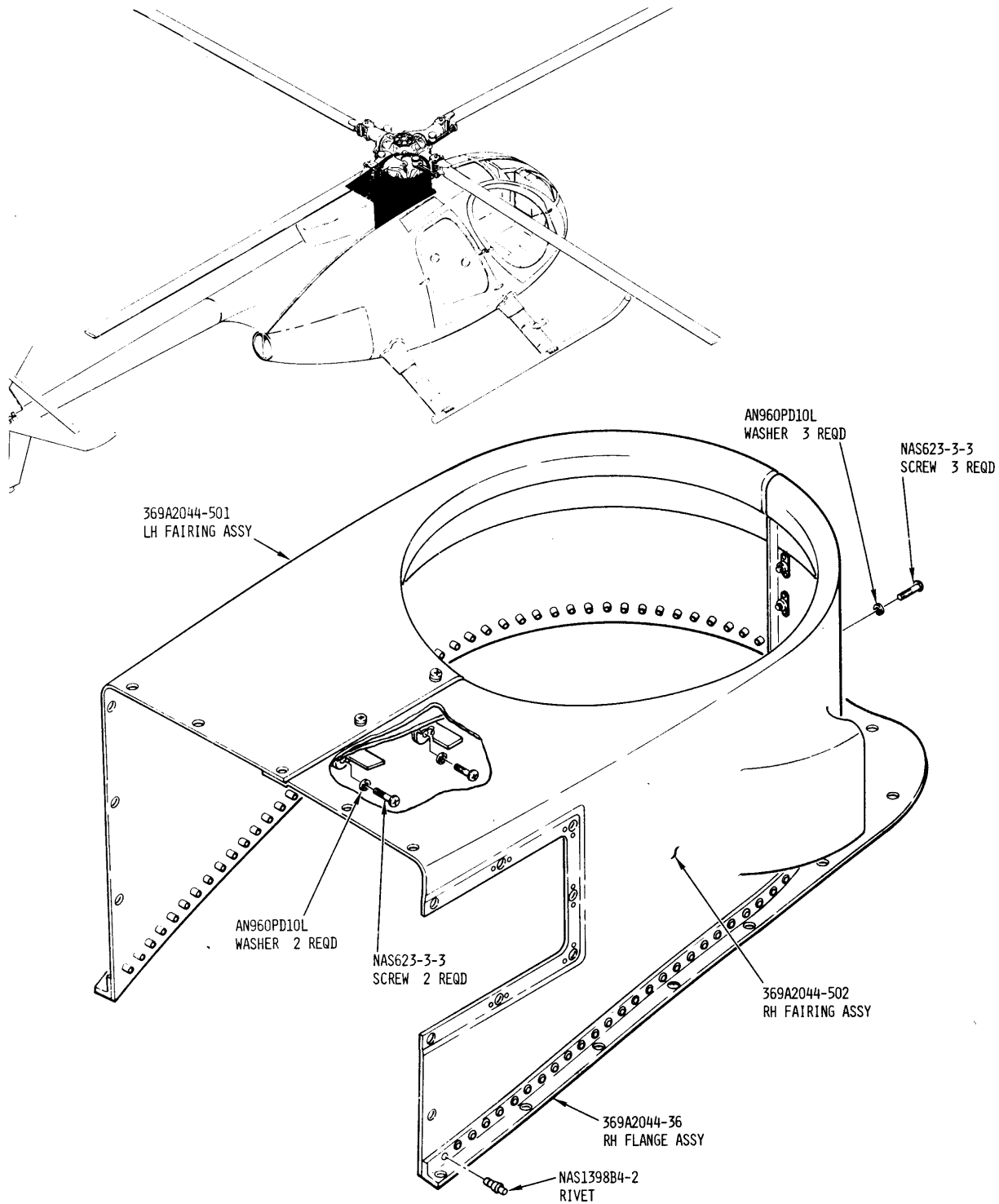

88-478

Figure 3. Engine Air Inlet Deflector Kit for 369H Series Helicopters

TECHNICAL BULLETIN

DATE: 21 APRIL 1981
PAGE 9 OF 9

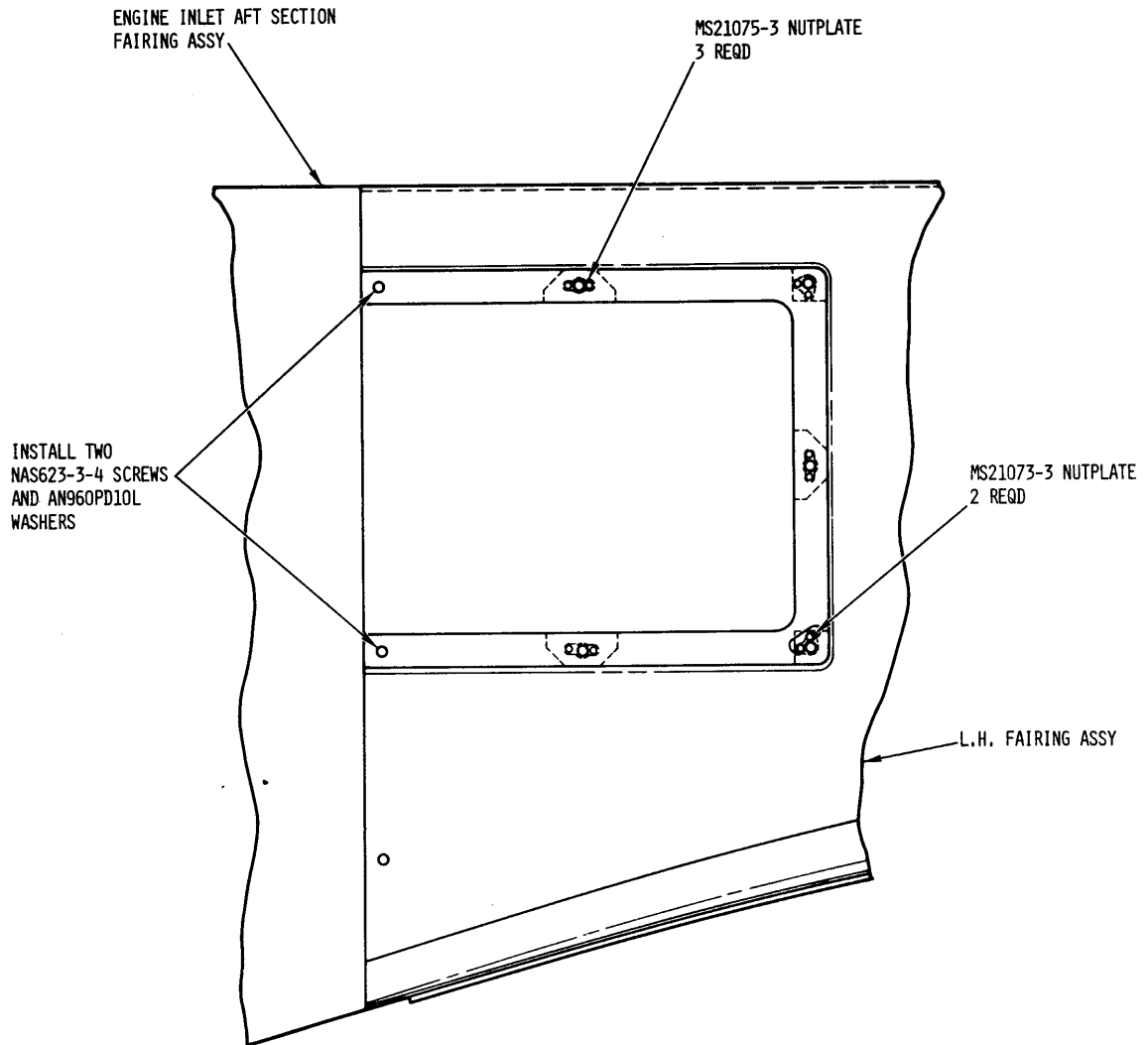

Figure 4. Tail Rotor Access Door Installation Details