



TECHNICAL BULLETIN

DATE: 24 NOVEMBER 1980
PAGE 1 OF 9

* Supersedes Service Information Notice No. HN-129, dated 3 Sept. 1978.

INSTALLATION OF ANTI-ICE FUEL FILTER, PN 369H90022-501

1. PLANNING INFORMATION

A. Models Affected

500C Model 369HS Helicopter Serial No. 0201S and subs equipped with PN 369H4260 or 369H6416 Instrument Panel

B. Time of Compliance

At owners and operators discretion -

Installation of the PN 369H90022 anti-ice fuel filter deletes the requirements for use of fuel containing anti-ice additive.

C. Preface

The information given in this Service Information Notice provides instructions for incorporating an anti-ice fuel filter between the helicopter fuel system and the engine fuel system. The filter is designed to strip the fuel of ice particles prior to entering the engine fuel system. Electrical and mechanical equipment sense the build up of ice in the filter unit, and automatically illuminate a cockpit caution and activate the helicopter start pump. When the filter becomes fully clogged, a bypass valve contained in the filter unit opens and the fuel bypasses the anti-ice fuel filter element.

D. Reference

00 Series - Basic HMI, Issued I October 1972; Revision No. 7, 15 December 1976

E. Weight and Balance

| Add/Subtract | Weight (lbs.) | Arm (inches) | Moment (inch-pounds) |
|--------------|---------------|--------------|----------------------|
| Add | 7.7 | 7.0 | 863 |

(I) Denotes portion of text added or revised.

DATE: 24 NOVEMBER 1980

PAGE 2 OF 9

TECHNICAL BULLETIN

F. Parts List

When ordering, specify PN 369H90022-501 Anti-ice Fuel Filter Installation which consists of the following:

| REPLACEMENT PARTS/SUPPLIES | | | |
|-------------------------------------|-------------|------|------------|
| Nomenclature | Part No. | Qty. | Source |
| Doubler | 369H90022-1 | 1 | HH |
| Tube | 369H90022-3 | 1 | HH |
| Filter Assembly | 369H8021 | 1 | HH |
| Fitting | 369H8023 | 1 | HH |
| Hose Assembly | 369H8024-5 | 1 | HH |
| Hose Assembly | 369H8025 | 1 | HH |
| Bracket | 369H8032 | 1 | HH |
| Insulation and Sealing Installation | 369H8033 -3 | 1 | HH |
| Placard | 369H8100 | 1 | HH |
| Drain Valve | CAV-170H-4 | 1 | Commercial |
| Tie Wrap | TY-25M | 1 | Commercial |
| Tee | 6151-0250 | 1 | Commercial |
| Clamp | AN737TW38 | 2 | Commercial |
| Bolt | AN775-4 | 1 | Commercial |
| Gasket | AN901-4A | 2 | Commercial |
| Reducer | AN919-19 | 2 | Commercial |
| Washer | AN960PD416L | 3 | Commercial |
| Washer | AN960PD10L | 2 | Commercial |
| Washer | AN960-10 | 4 | Commercial |
| Rivet | MS20615-3M | 30 | Commercial |
| Rivet | MS20615-4M | 10 | Commercial |
| Lockwire | MS20995C32 | AR | Commercial |
| Nut | MS2 1042-3 | 5 | Commercial |
| Clamp | MS21919H2 | 5 | Commercial |
| Packing | MS29512-04 | 1 | Commercial |
| Packing | MS29512-012 | 2 | Commercial |
| Screw | NAS603-7 | 5 | Commercial |
| Bolt | NAS304-5H | 3 | Commercial |
| Spacer | NAS43DD4-19 | 3 | Commercial |

TECHNICAL BULLETIN

DATE: 24 NOVEMBER 1980

PAGE 3 OF 9

| REPLACEMENT PARTS/SUPPLIES (Cont.) | | | |
|--|----------------|------|-------------|
| Nomenclature | Part No. | Qty. | Source |
| Anti-Ice Fuel Filter Electrical Installation: | 369H90161 | | |
| Harness Assembly | 369H90161-3 | 1 | HH |
| Panel | 369H4735 "A" | 1 | HH |
| Cover | 369H4739 | 1 | HH |
| Rivnut | S10K80 | 3 | BF Goodrich |
| Washer | AN960PD10L | 3 | Commercial |
| Spacer | NAS43DD3-10 | 3 | Commercial |
| Screw | NAS603-8 | 3 | Commercial |
| Screw | SFSW8CP-L01 BK | 5 | Commercial |
| Sleeve | MS21266-2 | AR | Commercial |
| Rotorcraft Flight Manual Supplement | CSP-D-II | 1 | HH |

G. Tools, Equipment and Materials

| TOOLS AND EQUIPMENT | | |
|-----------------------|---------------------------------|-------------|
| Nomenclature | Part Number | Source |
| Rivnut | C800 Heading Tool or equivalent | BF Goodrich |
| Rivet gun | | |
| Cutting shears | | |
| Drill motor, portable | | |
| Drill bit - No. G | | |
| Drill bit - No. 2 | | |
| Drill bit - No. 30 | | |

| MATERIALS | | | |
|-----------------------|-------------------------------|---------------------------|-----------------------------------|
| Nomenclature | Part Number/ Specification | Commercial Name | Source |
| Anti-seize compound | MIL-T-5544B | Thread Lube or equivalent | Parker -Hannifin Cleveland, OH |
| Sealant | MIL-S-8660B | 732RTV or equivalent | Dow Corning |
| Primer, zinc chromate | MIL-P-8585 | | Commercial |

DATE: 24 NOVEMBER 1980

PAGE 4 OF 9

TECHNICAL BULLETIN

2. INSTALLATION PROCEDURE

A. Helicopter Safety Procedures

WARNING

Prior to performing modification of fuel system, perform the Following to avoid possibility of fuel vapor ignition or fire:

- (1). Turn OFF all electrical power
- (2). Electrically ground helicopter {Section 2, Basic HMI}
- (3). Disconnect battery and external power {Section 17}

B. Access

NOTE: Perform the following to gain access to work areas:

- (1). Open engine access doors (Section 2)
- (2). Remove aft compartment seats; remove upper LH aft bulkhead panel and lower aft bulkhead panel (Section 4).
- (3). Remove pilot compartment LH floor access door (Section 2)
- (4). Remove instrument panel hood and instrument panel LH side fairing (Section 17)

C. Part I - Installation of Anti-Ice Fuel Filter

- (1). Close fuel shut off valve; drain fuel from supply line drain valve. (Section 2, Basic HMI.)
- (2). Disconnect and remove existing fuel supply hose from engine driven fuel pump and from elbow on Station 125.0 firewall fitting. (Section 12, Basic HMI.)
- (3). Using existing rivet locations on Station 124.0 firewall, drill 0.125-inch diameter holes and install doubler on FORWARD side of firewall as shown. Install rivets with zinc chromate primer. (View A-A, and A, Figure 1.)
- (4). Using 369H8032 bracket as template, mark and drill 0.1285-inch diameter rivet holes and install bracket on AFT side of firewall as shown. Use existing rivet pattern as applicable. Install rivets with zinc chromate primer.
- (5). Install four 369H8033 insulation panels on AFT side of firewall as shown.
 - (a). Clean firewall area free of dirt, grease, grit, etc.
 - (b). Apply thin film of 732 RTV sealant to entire bonding surface of insulation panels.
 - (c). Gently press panels in place on firewall; work from center outward in all directions. Do not use excessive pressure or collapse of insulation panel will occur. Cure time is 24 hours.
- (6). Remove 369H8050-11 clip securing engine gearcase cooling duct to fuselage structure; drill 0.260-inch diameter hole and relocate clip on structure per dimension shown.
- (7). Install 569H8021 filter assembly in bracket with three bolts and washers as shown; lockwire bolts.
- (8). Connect new 369H8024-5 hose with firesleeve to filter and to engine driven fuel pump as shown.

TECHNICAL BULLETIN

DATE: 24 NOVEMBER 1980

PAGE 5 OF 9

- (9). Connect new 369H8025 hose with fire sleeve to filter and to existing 369H8103 fitting and elbow on firewall; reposition fitting and elbow as shown. As required, install clamp on hose and secure clamp to stiffener, to prevent chafing of hose on structure.
- (10). Install new CAV-170H-4 valve with packing to filter, using anti-seize compound. Install new 369H90022-3 drain tube to valve with lockwire.
- (11). Splice new 6151-0250 tee into existing drain tube arrangement as shown; allow slack to permit unrestrained movement of drain tube. For helicopter with 369H92255 drain kit installed, reposition existing tee as shown.
- (12). Connect other end of 369H90022-3 drain tube to tee with lockwire.
- (13). Route 369H90161-3 wiring harness from filter down and aft, then forward through 369H2500 conduit left side. Install clamps four places at existing tooling holes in structure as shown; secure wiring harness with clamps. Route wiring forward through conduit to pilot compartment.

D. Part II - Electrical Installation

- (1). Using 369H4735 panel as template, mark and drill three 0.219-inch diameter holes in LH side of instrument console as shown in Figure 2; install rivnuts.

NOTE: Use existing nutplate and/or hole as reference point.

- (2). Install 369H4735 Panel on LH side of instrument console, using three screws, washers and spacers as shown.
- (3). Route filter wiring harness from conduit to instrument console; tie in with existing wiring harness.
- (4). Connect electrical wiring per wiring diagram and wire table.
- (5). Reconnect battery and perform ground operational check of anti-ice fuel filter installation. (Refer to Section II of RFM Supplement.)
- (6). Record helicopter serial number on 369H8100 placard; install placard on overhead duct in pilot compartment at location shown.
- (7). Install 369H4739 cover on 369H4735 panel, using five screws.
- (8). Make cutout in instrument console LH fairing as shown; reinstall fairing.
- (9). Make cutout in instrument console hood as shown; reinstall hood.
- (10). Reseal both ends of 369H2500 conduit with 732RTV sealant.
- (11). Reinstall removed components and access doors and panels.
- (12). Insert Rotorcraft Flight Manual Supplement in Section IX of flight manual.
- (13). Record installation of 369H90022-501 anti-ice fuel filter installation in Components Record of helicopter Log Book.

DATE: 24 NOVEMBER 1980
PAGE 6 OF 9

TECHNICAL BULLETIN

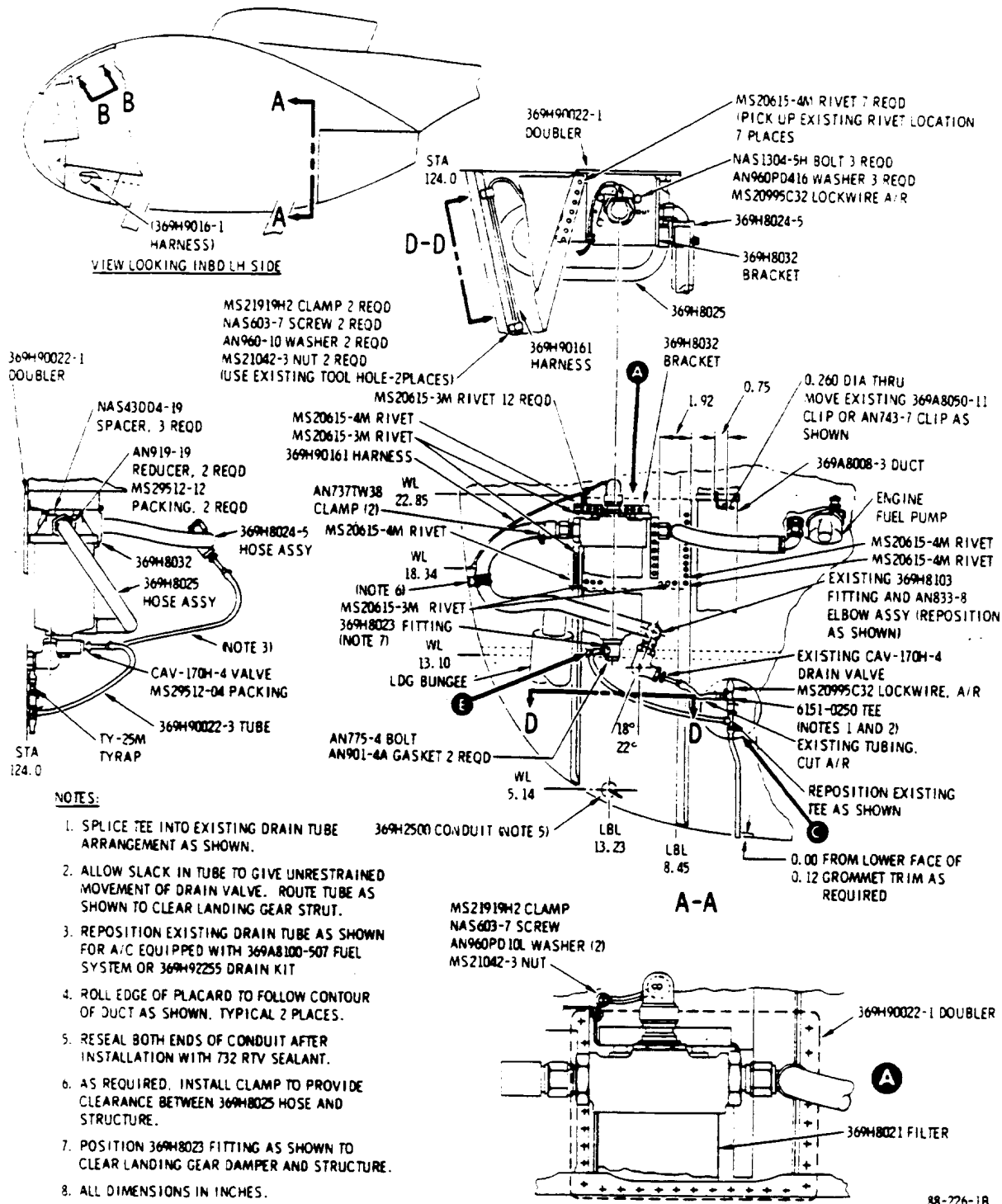

88-226-1B

Figure 1. Installation - 369H90022 Anti-Ice Filter (Sheet 1 of 2)

TECHNICAL BULLETIN

DATE: 24 NOVEMBER 1980

PAGE 7 OF 9

B INSTALLATION 369H8033 INSULATOR PANELS
 VIEW LOOKING FWD (AT STA 124.00) (FLANGES
 & COVERS ON INSULATOR ASSY OMITTED FOR
 CLARITY

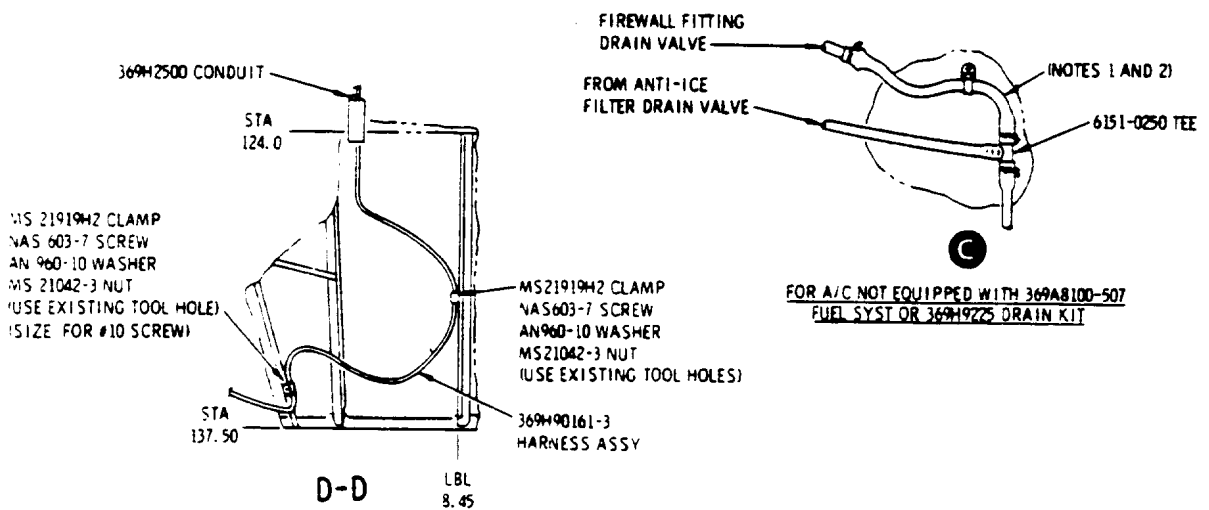
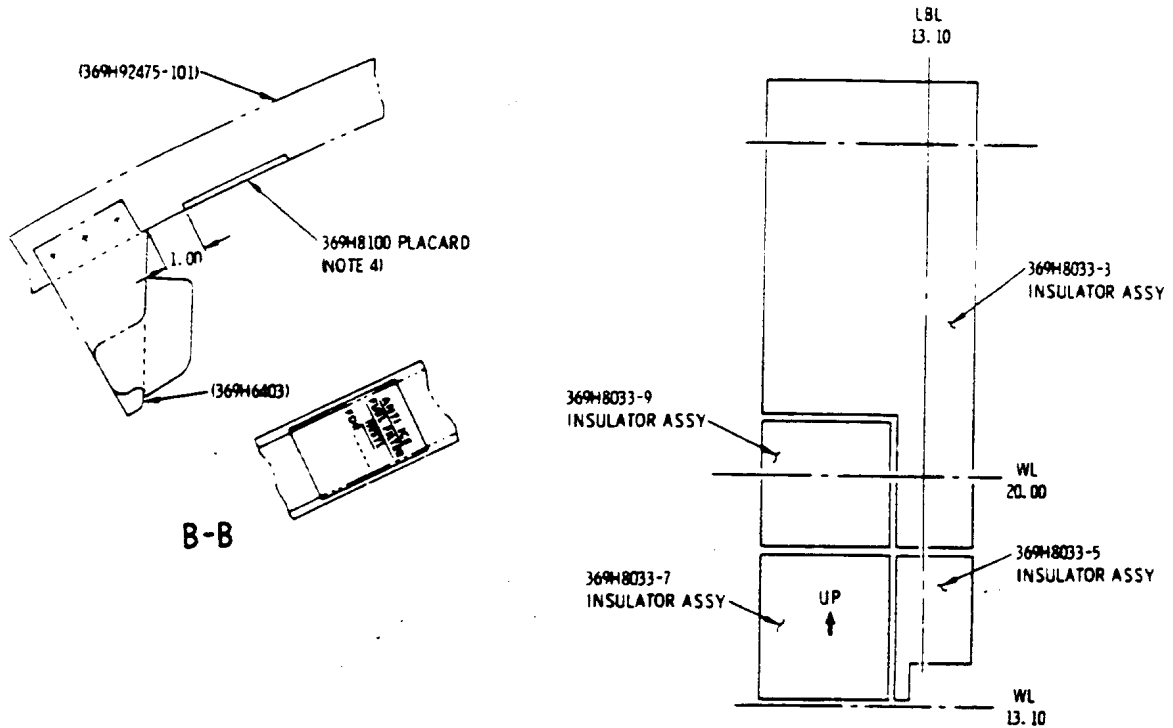

Figure 1. Installation - 369H90022 Anti-Ice Fuel Filter (Sheet 2 of 2)

DATE: 24 NOVEMBER 1980

PAGE 8 OF 9

TECHNICAL BULLETIN

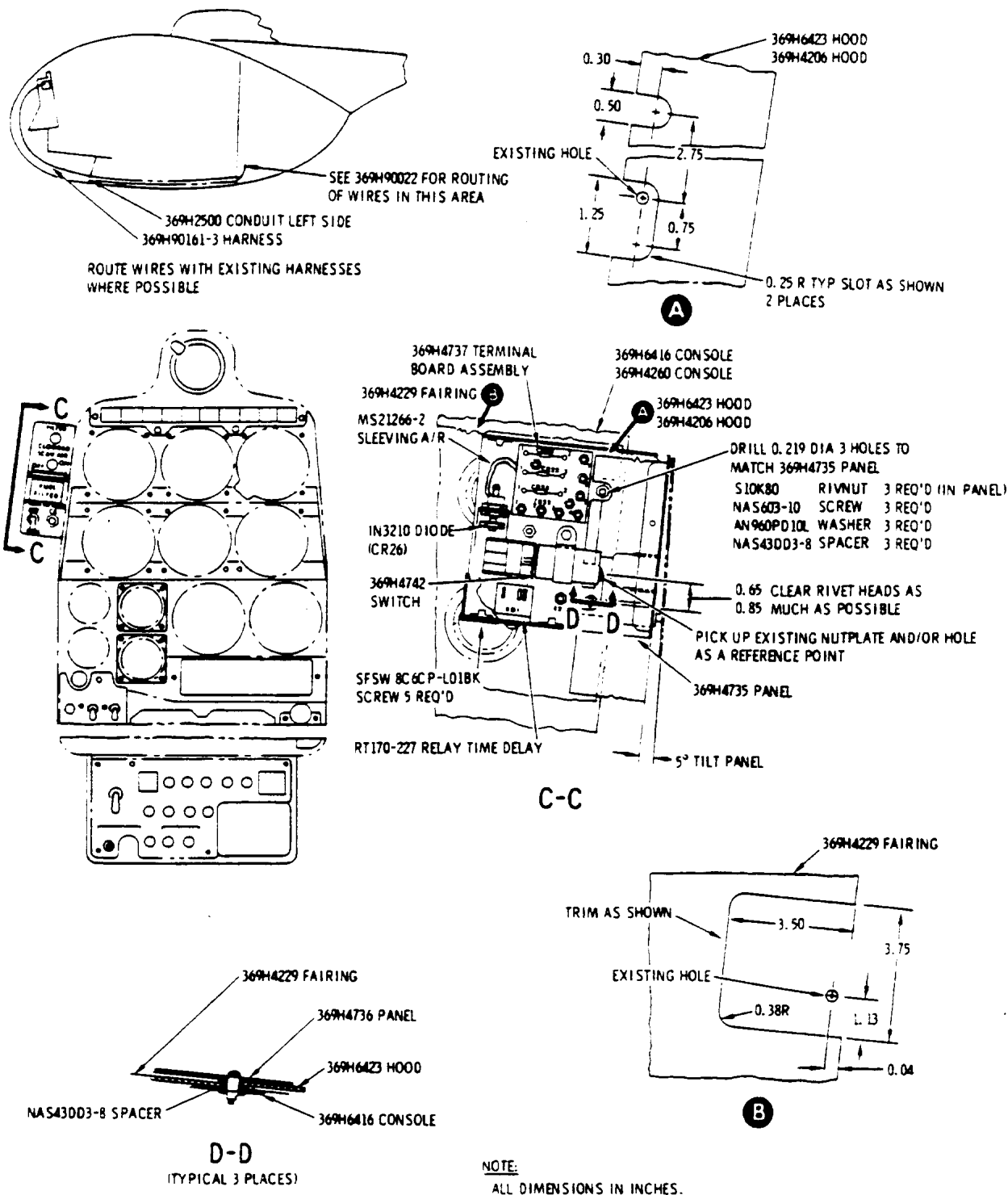

Figure 2. Electrical Installation - 369H90022 Anti-Ice Fuel Filter (Sheet 1 of 2)

TECHNICAL BULLETIN

DATE: 24 NOVEMBER 1980

PAGE 9 OF 9

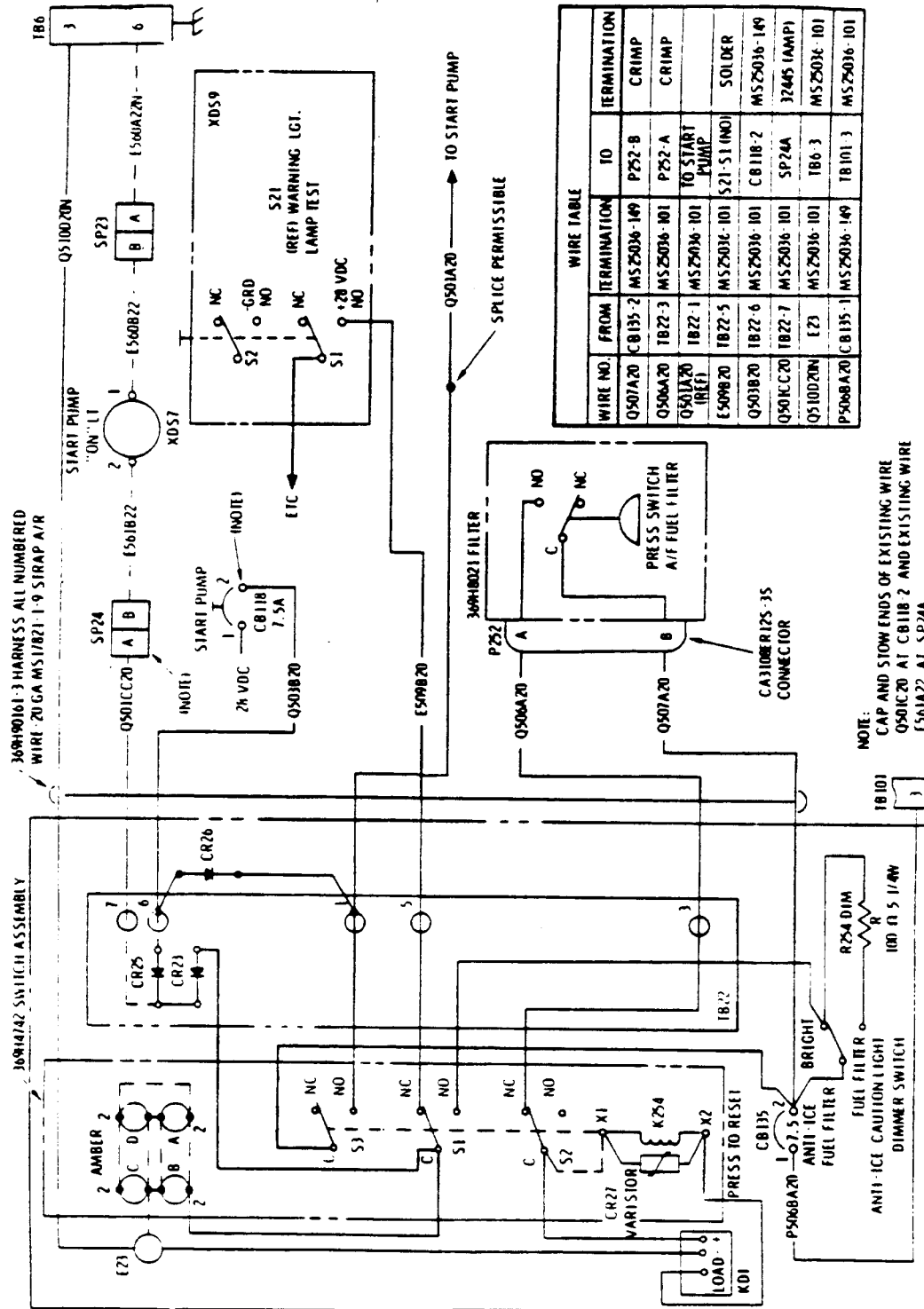

Figure 2. Electrical Installation - 369H90022 Anti-Ice Fuel Filter (Sheet 2 of 2)