



TECHNICAL BULLETIN

DATE: 24 DECEMBER 1976
PAGE 1 OF 5

TACHOMETER GENERATOR ASSEMBLY – MODIFICATION KIT PN M50049

1. PLANNING INFORMATION:

A. Models Affected:

Model 369HS Helicopter Serial No. 0001S and subsequent Model 369HM Helicopter Serial No. 0201M and subsequent

B. Time of Compliance:

At Owner's and Operator's discretion

C. Preface:

The information given in this Service Information Notice lists a procedure, for optional field modification of the N1, N2 and NR tachometer generator installed on the above affected helicopters. The rework kit provides an alternative wiring method in event connector pins on the generator plug cap are broken or damaged, thus permitting continued use of the tach generator in service.

D. Weight and Balance:

Weight and balance not affected.

E. Reference Publications:

500 Series - Basic HMI, Issued 1 October 1972; Revision No. 6, 1 November 1976
500 Series - Configuration Supplement S/E, Issued 1 May 1970; Revision No. 2, 1 October 1973, 500 Series - Configuration Supplement M, Issued 1 December 1971; Revision No. 3, 1 October 1974; Revised Change Pages, 15 March 1975

REPLACEMENT PARTS/SUPPLIES			
Nomenclature	Part No.	Qty.	Source
Wiring Harness	M50449-3	3	HH
Knife splice	32445	6	Commercial
Wire	20 GA (MIL-W-7139)	A/R	Commercial
Sleeving	No.8 Vargiss	A/R	Commercial
Sleeving	Thermofit RNF (100 x 2.5 ID)	A/R	Commercial

MATERIAL	
Nomenclature	Source
Potting compound (3C-3007 or MIL-S-8516)	Churchill Chemical Co.
Lacing cord (T-3333)	Warren Wire Co.

DATE: 24 DECEMBER 1976
PAGE 2 OF 5

TECHNICAL BULLETIN

MATERIAL (Cont.)	
Nomenclature	Source
Silicone adhesive/sealant (RTV 732 or equiv.)	Dow Corning Corp.
Solder (SN60WRP2) QQ-S-571	Commercial
Methylethylketone or equiv.	Commercial

TOOLS AND EQUIPMENT	
Nomenclature	Source
Drill motor, portable	Commercial
Drill bit – #30	Commercial

2. MODIFICATION PROCEDURE

- (1). Remove N1, N2 and/or NR tachometer generator from helicopter, per Basic HMI



Do not remove "rotor" from generator housing at any time during modification.

- (2). Remove snap ring securing rear plug cap to generator; disconnect (unsolder) black and white wires from connector pin sockets.
- (3). Cut five connector pins from connector plug, as shown; cover bare metal with adhesive/sealant.
- (4). Drill 0.124/0.129 inch diameter hole in plug cap, per dimensions shown.
- (5). Clean plug area around connector pin sockets with MEK or equivalent.

NOTE: It is permissible to connect "A" and "B" wires directly to white and black wires, respectively, inside of plug cap.

- (6). Insert assembled M50449 harness wiring through hole in plug cap. Solder wire "A" to remaining portion of Pin A inside of cap; solder wire "B" to remaining portion of Pin B inside of cap.
- (7). Coat area around soldered connections with adhesive/sealant to provide bond for potting compound.
- (8). Fill cavity in plug cap with potting compound; allow to cure for 8 hours minimum.
- (9). Reinstall rear plug cap on generators; secure with snap ring.
- (10). Rework 369H4147 engine wiring harness and 369H4121 gearbox and aft fuselage harness assembly as follows (see Figure 1):
 - (a). Remove 369A4599 plug and hood from wiring harness.
 - (b). Install identification sleeves (A and B), knife splices and Varglas sleeving.
 - (c). Tie Varglas sleeving with cord.



HN-113

TECHNICAL BULLETIN

DATE: 24 DECEMBER 1976
PAGE 3 OF 5

- (11). Test tachometer generator, per Basic HMI.
- (12). Reinstall tachometer generator, per Basic HMI; connect engine and tach generator wiring harnesses at knife splices.

DATE: 24 DECEMBER 1976
PAGE 4 OF 5

TECHNICAL BULLETIN

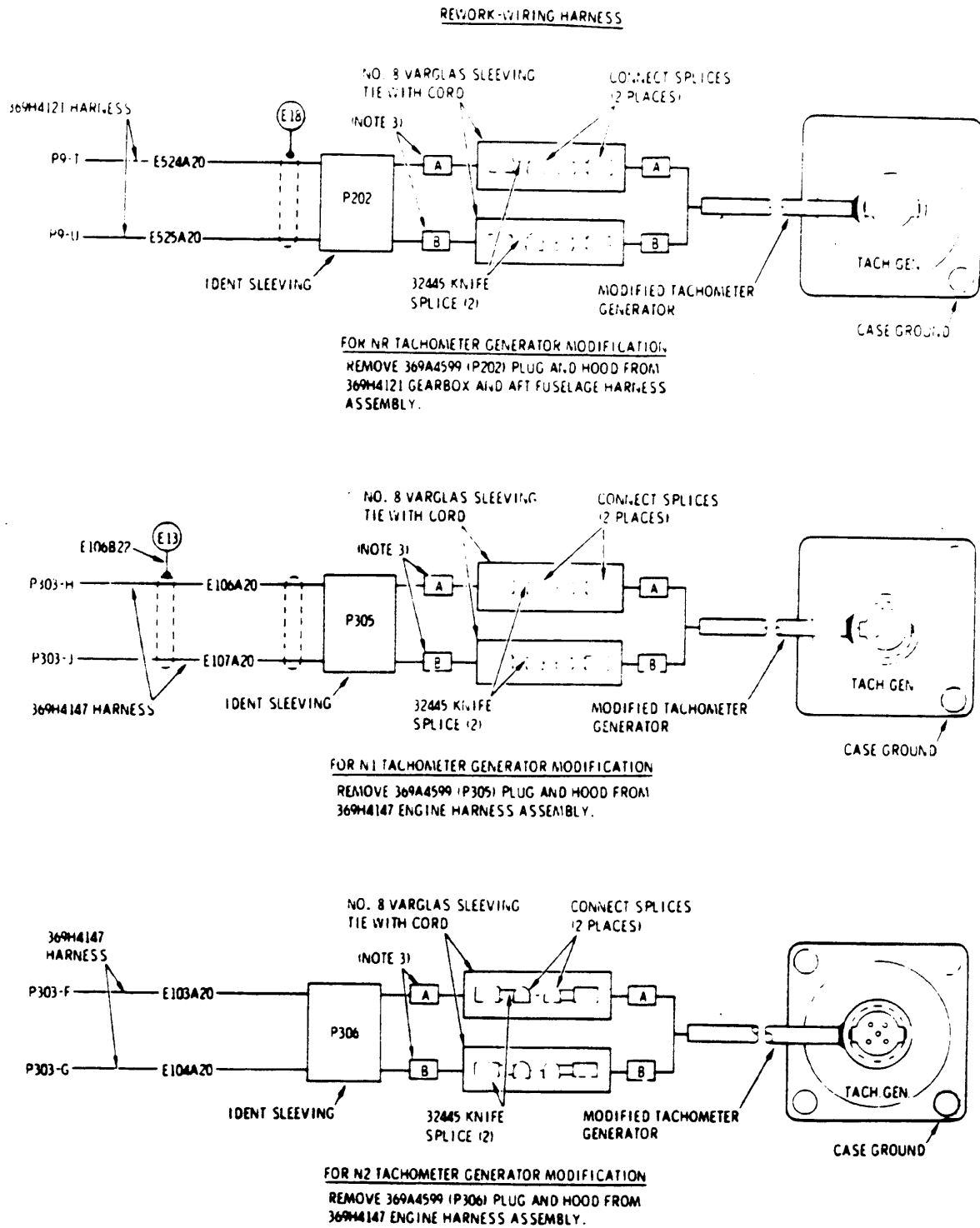

88-198-1

Figure 1. Field rework - tachometer generator inst. Mod. Kit, PN M50449 (sht 1 of 2)

TECHNICAL BULLETIN

DATE: 24 DECEMBER 1976
PAGE 5 OF 5

REWORK-TACHOMETER GENERATOR

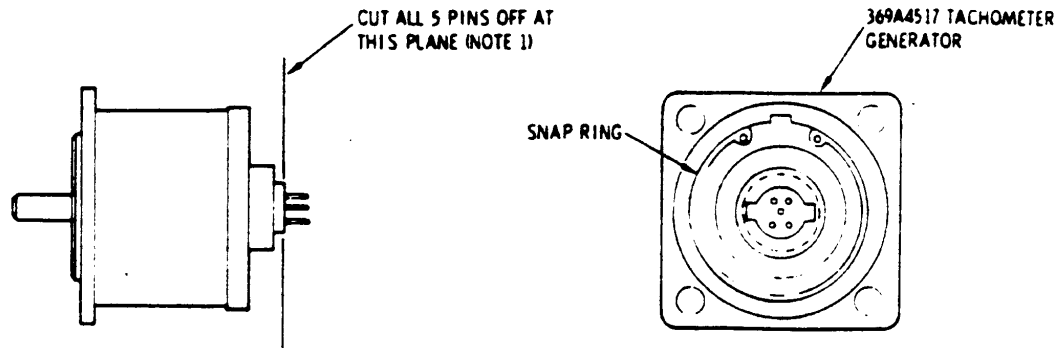

CAUTION:

DO NOT REMOVE "ROTOR" FROM GENERATOR HOUSING AT ANY-TIME DURING MODIFICATION.

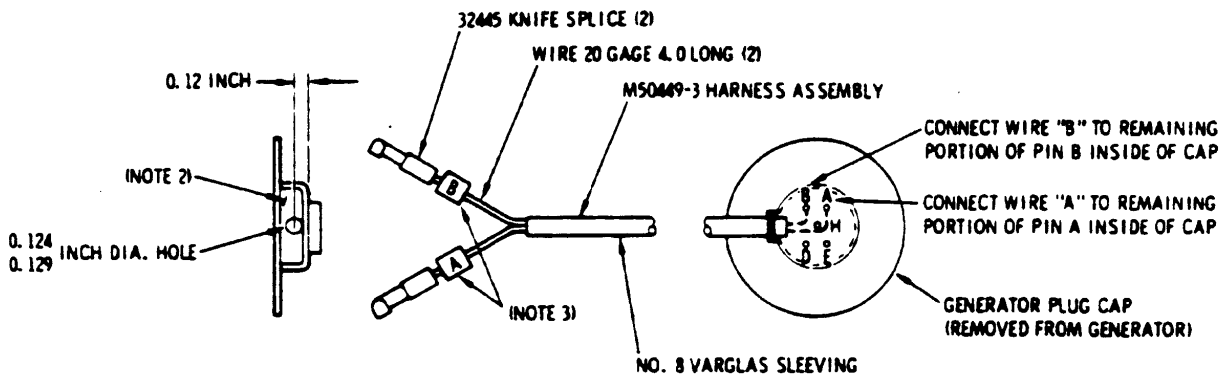

NOTES:

1. COVER BARE METAL WITH ADHESIVE/SEALANT.
2. FILL CAVITY WITH POTTING COMPOUND AFTER ASSEMBLY OF WIRE AND SLEEVING.
3. IDENTIFY AS SHOWN.

88-108-2

Figure 2. Field rework - tachometer generator inst. Mod. Kit, PN M50449 (sheet 2 of 2)