

# TECHNICAL BULLETIN

DATE: 24 DECEMBER 1976  
PAGE 1 OF 3

## FIELD FIX FOR MAIN ROTOR SWASHPLATE UNIBALL

### 1. PLANNING INFORMATION:

#### A. Models Affected:

All 500 Model 369H Series Helicopters

#### B. Time of Compliance:

At Owner's and Operator's discretion

#### C. Preface:

Field reports indicate that there have been isolated instances of pilots experiencing stiff main rotor controls caused by an excessive preload torque on the main rotor swashplate (Uniball) bearings. The high loading or "stiff ball" condition resulted from swelling of the bearing liner, particularly with bearings operating in a hot and extremely humid climate.

The information given in this Service Information Notice lists a procedure for reworking the bearing liner, if "stiff ball" condition exists, to reduce the preload torque and restore normal main rotor control response.

#### D. Reference Publications:

500 Series - Basic HMI, issued 1 October 1972; Revision No. 6, 1 November 1976

MATERIAL	
Nomenclature	Source
Abrasive paper - #400	Commercial
Isopropyl alcohol	Commercial

TOOLS AND EQUIPMENT	
Nomenclature	Source
Oven, heat treating or equivalent	Commercial

### 2. REWORK - MAIN ROTOR SWASHPLATE BEARING, PN 369A7003

- (1). Remove and inspect main rotor swashplate assembly, per Basic HMI; do not disassemble swashplate assembly.
- (2). Place swashplate assembly in oven at temperature of 225° ±10° F for minimum of five hours. -Do not exceed oven temperature of 240° F.
- (3). Cool swashplate assembly to room temperature (approximately 70' F).
- (4). Using #400 wet and dry abrasive paper, sand both edges of bearing liner, as shown in Figure 1.

DATE: 24 DECEMBER 1976  
PAGE 2 OF 3

# TECHNICAL BULLETIN

- (5). Clean entire liner with isopropyl alcohol after rework.
- (6). Reinstall main rotor swashplate assembly, per Basic
- (7). Perform operational check of main rotor controls. NOTE

**NOTE:** If stiff main rotor controls persist, replace swashplate bearing.

# TECHNICAL BULLETIN

DATE: 24 DECEMBER 1976  
PAGE 3 OF 3

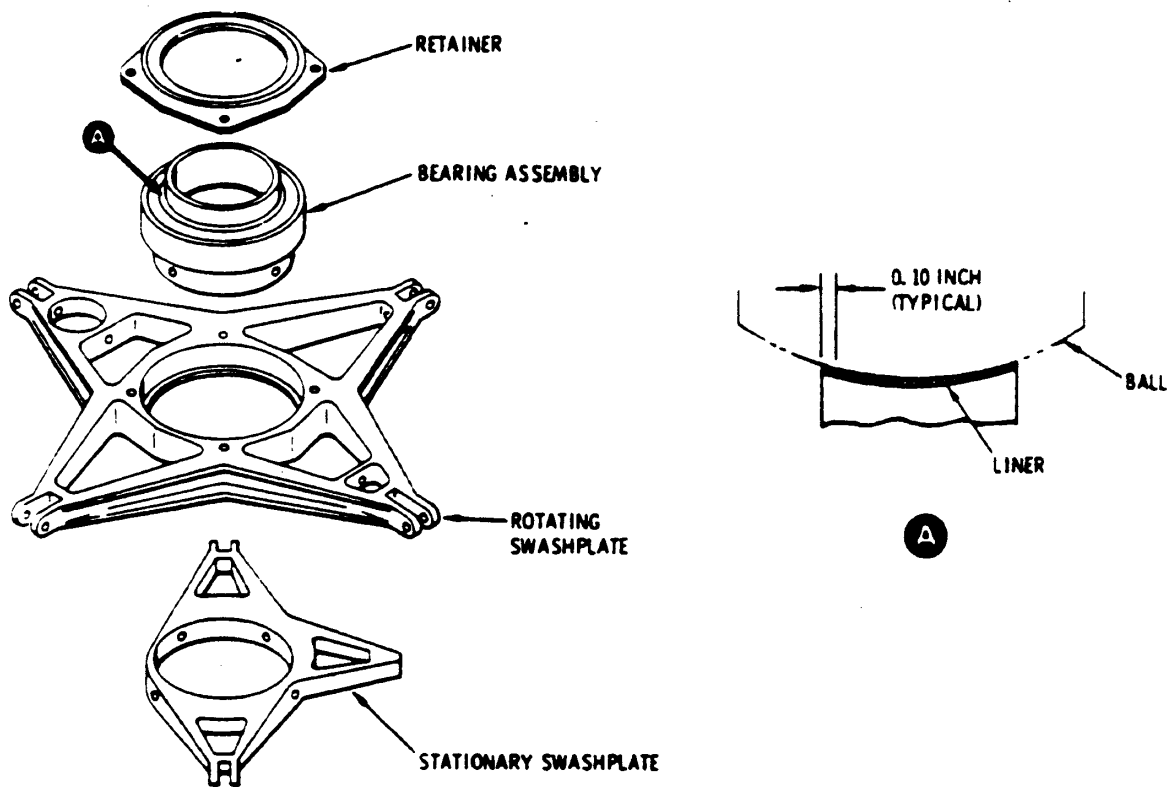

88-200

**Figure 1. Field Rework of Main Rotor Swashplate Bearing, PN 369A7003**