



DN-55

# TECHNICAL BULLETIN

DATE: 20 AUGUST 1979  
PAGE 1 OF 3

**SUBJECT:** REWORK OF GROUND HANDLING WHEEL ASSEMBLIES (FLOAT TYPE)

**MODELS AFFECTED:** All float type ground handling wheel assemblies not equipped with wheel fender guards\*.

**TIME OF COMPLIANCE:** At owners and operators discretion.

**PREFACE:** Field reports indicate that chafing and damage to floats, and/or shearing of the bolts attaching the floats and gravel guards to the landing gear skids, have occurred when using early type ground handling wheel assemblies that do not have protective fender guards,

The information given in this Notice lists instructions for reworking the early float type ground handling wheel assemblies, to add wheel fender guards and protective padding to help prevent handling damage.

\*It is to be noted that PN 369H90126-1 and -2 ground handling wheel assemblies incorporate the wheel fender guards and padding and do not require rework per this Notice.

**REFERENCE PUBLICATIONS:**

500D Basic HMI-Volume I, Issued 15 September 1976; Revision No. 3, 15 March 1979.

# TECHNICAL BULLETIN

## MATERIALS

Neoprene rubber sheet- 0.12 x 2.50 x 16.50	COMMERCIAL
Rubber cement	Grip Taylor Industry
	Lockbond Industrial Rubber Cement Co.
	EC1300L 3M Co.
Al Aly Sheet (2) -- 0.092 x 2.50 x 6.00	6061-O;QQ-A-25/11; Temp 0
Al Aly Sheet (2) -- 0.093 x 3.25 x 6.00	6061-O;QQ-A-25/11; Temp 0

## TOOLS AND EQUIPMENT

Welding equipment

Shears or saw, metal cutting

Grinder, portable

## REWORK OF GROUND HANDLING WHEELS

- a. Fabricate fender guards (2) and supports (2) per dimensions shown in Figure 1; bend supports 30 degrees as shown; weld supports to fender guards.
- b. Cut off existing channel to 0.75 inch dimension shown.
- c. Weld fender guard assemblies in place on wheel assembly.
- d. Clean channel and bond neoprene rubber sheet to channel.
- e. Grind off burrs or sharp edges on fender guards and channel.

# TECHNICAL BULLETIN

DATE: 20 AUGUST 1979  
PAGE 3 OF 3

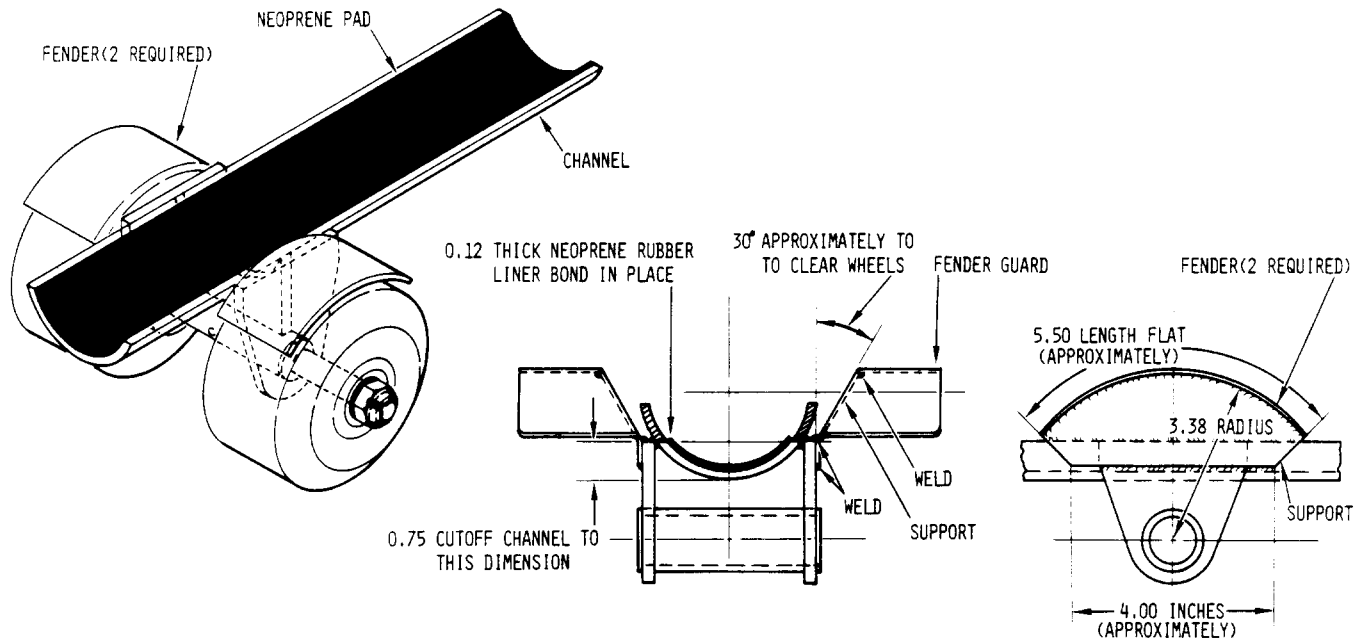

ADN55-1

Figure 1. Rework of Ground Handling Wheel Assemblies