



SERVICE BULLETIN

DATE: 11 JANUARY 2000

PAGE 1 OF 6

/// MANDATORY ////////////////////////////////////// MANDATORY ////////////////////////////////////// MANDATORY ///

TURBINE OUTLET TEMPERATURE (TOT) INDICATING SYSTEM, ONE TIME INSPECTION

1. PLANNING INFORMATION

A. Aircraft Affected:

500N helicopters, S/N LN001 thru LN088, equipped with analog/digital TOT indicator
369E helicopters, S/N 001 thru 543, equipped with analog/digital TOT indicator
369D helicopters equipped with analog/digital TOT indicator.

B. Assembly/Components Affected By This Notice:

The TC300 terminal block located over the left-hand engine bay door.
P1202J connector located in the battery compartment.
P5 connector located on TOT indicator.

C. Reason:

There have been reports from the field of erroneous turbine outlet temperature (TOT) readings on aircraft equipped with analog/digital TOT indicators. To verify TOT system calibration and prevent the possibility of erroneous TOT indications. Failure to perform the requirements of this Bulletin may result in a condition that could damage critical engine components.

D. Description:

Procedures in this Bulletin provide owners and operators with information pertaining to verifying the installation of proper termination hardware in the aircraft TOT wiring circuitry.

E. Time of Compliance:

The requirements of this Bulletin shall be accomplished within the next 100 hours of helicopter operation or no later than 15 March 2000.

F. FAA Approval:

The technical design aspects of this Bulletin are FAA Approved.

G. Manpower:

Part I: 0.5 man-hours
Part II: 3.0 man-hours

H. Interchangeability:

None

/// MANDATORY ////////////////////////////////////// MANDATORY ////////////////////////////////////// MANDATORY ///



DATE: 11 JANUARY 2000
PAGE 2 OF 6

SERVICE BULLETIN

MANDATORY

I. Material/Part Availability:

Contact MDHI Warranty and Repair Dept.

NOTE: Parts are individually packaged. Do not remove from package until you are ready to install. Terminal sockets may be impossible to distinguish from each other.

REPLACEMENT PARTS/SUPPLIES			
Nomenclature	Part No.	Qty.	Source
Terminal Lug, Chromel (stud size #8)	1-321897-0	1	MDHI
Terminal Lug, Alumel (stud size #10)	1-321898-0	1	MDHI
Terminal Pin, Chromel	M39029/87-480	1	MDHI
Terminal Pin, Alumel	M39029/87-479	1	MDHI
Terminal Socket, Chromel	M39029/88-492	1	MDHI
Terminal Socket, Alumel	M39029/88-491	1	MDHI
Terminal Socket, Chromel	M39029/32-245	1	MDHI
Terminal Socket, Alumel	M39029/32-244	1	MDHI

TOOLS AND EQUIPMENT	
Nomenclature	Source
Crimping tool P/N 46673-L (for terminal lugs)	AMP Inc. 441 Friendship Rd. Harrisburg, PA 17111 Phone: (717) 564-0100 FAX: (717) 986-7575
Crimping tool P/N MS22520/1-01	Daniels Manufacturing Corp. 526 Thorpe Road Orlando, FL 32824 Phone: (407) 855-6161 FAX: (407) 855-6884
Positioner P/N MS22520/1-02 (for M39029/10-140, -141 sockets)	Daniels
Positioner P/N MS22520/1-04 (for M39029/88-491, -492 sockets, and M39029/87-479, -480 pins)	Daniels
Thermocouple tester Fluke, Model No. 714	Fluke Corp. P.O. Box 9090 Everett, WA 98206 Phone: (425) 347-6100 FAX: (425) 356-5116

MANDATORY

SERVICE BULLETIN

DATE: 11 JANUARY 2000

PAGE 3 OF 6

MANDATORY

TOOLS AND EQUIPMENT (Cont.)	
Nomenclature	Source
Omega, Model No. CL-307A-K	OMEGA Engineering Inc. One Omega Drive, Box 4047 Stanford, CT 06907-0047 Phone: (203) 359-1660 FAX: (203) 359-7700
Barfield, Model No. TT-1000A	Barfield Instrument Corp. P.O. Box 025367 Miami, FL 33102 Phone: (305) 871-3900 FAX: (305) 871-5629

J. Warranty Policy:

Parts will be provided at no cost to the operators. Tools will not be provided by MD Helicopters. MD Helicopters will compensate operators for labor, via a spares credit, not to exceed three (3) hours.

K. Weight and Balance:

N/A

L. Other Publications Affected:

Latest revision of applicable Rolls Royce Allison Operation and Maintenance Manual.

2. ACCOMPLISHMENT INSTRUCTIONS

A. Part I

- (1). Disconnect the engine thermocouple wire harness at the TC300 terminal block located over the left-hand engine compartment door.
- (2). Connect tester (Ref. Figure 1) to TC300.
 - (a). Connect tester wire to #8 stud on TC300 (white chromel wire) (yellow lead for Fluke and Omega, red for Barfield).
 - (b). Connect tester wire to #10 stud on TC300 (green alumel wire) (red lead for Fluke and Omega, black for Barfield).



For Omega and Fluke testers, do not force lead into tester, one lead prong of plug is larger than the other, damage to tester connection will occur.

- (c). Connect lead to tester.
- (3). Set power switch to source for Omega and Fluke or ON position for Barfield.
- (4). Set indicator to temperatures in Table 1.
- (5). Turn on aircraft electrical power.

NOTE: TOT indicator requires approximately five seconds to reset internal circuitry.

MANDATORY



DATE: 11 JANUARY 2000
PAGE 4 OF 6

SERVICE BULLETIN

MANDATORY

- (6). Verify TOT gauge indicates same as tester, within tolerance (Ref. Table 1).
 - (a). If TOT indicator matches temperatures in Table 1, no further action is required.
 - (b). If TOT indicator does not match temperatures in Table 1;
 - 1). Refer to applicable Rolls Royce Allison Operation and Maintenance Manual for possible maintenance actions, if TOT gauge indicates 30° lower than tester.
 - 2). Perform Part II of this service bulletin.
- (7). Turn off aircraft electrical power.
- (8). Set source switch to off position.
- (9). Disconnect tester from TC300.
- (10). Reconnect engine thermocouple wire harness to TC300 terminal block.
- (11). Record compliance to the Service Bulletin in the Compliance Record section of the helicopter Log Book.

Table 1. TOT System Test

Tester Setting (°C)	Indicator Reading (°C)
700°	700° ±10°
725°	725° ±10°
752°	752° ±10°
810°	810° ±10°

B. Part II

NOTE: Terminal lugs and connector pins and sockets must be crimped on, no soldering allowed.

- (1). Disconnect the airframe thermocouple wire harness from the TC300 terminal block.
- (2). Using a magnet, verify that the terminal attached to the Chromel wire (white jacket) is not attracted to the magnet and that the terminal is silver (not gold) in color.
- (3). Using a magnet, verify that the terminal attached to the Alumel wire (green jacket) is attracted to the magnet and that the terminal is silver (not gold) in color.
- (4). If either is discrepant, replace the terminal lug(s) with the correct terminal lug(s).
- (5). Reconnect the airframe thermocouple wire harness to the TC300 terminal block.
- (6). Disconnect P1202 from J1202 in battery compartment.
- (7). Remove pins K and N from P1202.
- (8). Using a magnet, verify that pin N is magnetic and pin K is not magnetic and that the pins are silver (not gold) in color.
- (9). If either is discrepant, replace the pin(s) with the correct pin(s).
- (10). Reinstall pins in P1202.
- (11). Remove and replace sockets K and N from J1202.

MANDATORY

SERVICE BULLETIN

DATE: 11 JANUARY 2000

PAGE 5 OF 6

MANDATORY

- (12). Reconnect P1202 to J1202.
- (13). Disconnect P5 from TOT indicator.
- (14). Remove and replace sockets F and G from P5.
- (15). Reconnect P5 to TOT indicator.
- (16). Perform Part I of this bulletin again.

NOTE: If TOT indicating system fails again, replace the indicator and re-test the system.

- (17). After TOT system passes test, record compliance to the Service Bulletin in the Compliance Record section of the helicopter Log Book.

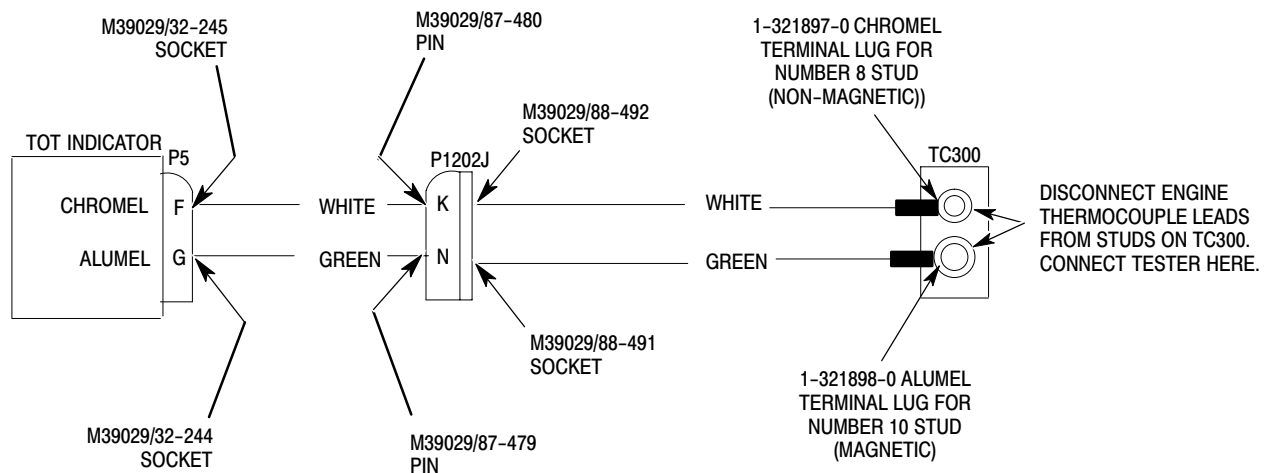

88-773-1

Figure 1. TOT Wire Harness Termination Verification

3. DISPOSITION OF PARTS REMOVED

Return indicators to MDHI for disposition.

NOTE: If instrument was not supplied by MDHI, return to vendor for disposition.

4. POINTS OF CONTACT

For further assistance, contact your local MDHI Field Service Representative (refer to the latest revision of the "At Your Service" handbook for address and telephone numbers) or contact the Field Service Department at MDHI, Mesa, Arizona. Telephone 1-800-388-3378 or (480) 891-6342. DATAFAX: (480) 891-6782.

MANDATORY



DATE: 11 JANUARY 2000
PAGE 6 OF 6

SERVICE BULLETIN

/// MANDATORY ////////////////////////////////////// MANDATORY ////////////////////////////////////// MANDATORY ///

Compliance Recording Form

Customer/Operator Name

Aircraft Serial No.

Helicopter Total Time

Date of Compliance

Signature of Person Confirming Compliance

FAX this form to MDHI (480) 891-6782

/// MANDATORY ////////////////////////////////////// MANDATORY ////////////////////////////////////// MANDATORY ///