



# SERVICE BULLETIN

DATE: 28 JULY 1981  
PAGE 1 OF 4

**MANDATORY**

\* Supersedes Service Information Notice No. DN-78, dated 14 January 1981

## INSPECTION OF PN 369A7003-3 SWASHPLATE BEARING

### 1. PLANNING INFORMATION

#### A. MODELS AFFECTED:

500D Model 369D helicopter Serial No. 0003D through 0830D

#### B. PREFACE:

The information given in this Service Information Notice lists a procedure for inspection of PN 369A7003-3 bearing assembly for cracks around mounting holes in the bearing sleeve.

#### C. TIME OF COMPLIANCE:

Shall be accomplished within next 300 hours of helicopter operation or at next annual inspection, whichever occurs first.

#### D. FAA APPROVAL:

FAA/DER APPROVED 29 July 1981

#### E. WEIGHT AND BALANCE:

Weight and balance not affected

#### F. REFERENCE:

500D Model 369D Basic HMI-Vol I, Issued 15 September 1976, Revision No. 15 May 1981 500D Model 369D Component Overhaul Manual, Issued 15 September 1976

#### G. PARTS LIST:

PARTS LIST			
Nomenclature	Part No.	Qty.	Source
Bearing Assembly*	369A7003-3	1	HH
Washer	369A1605-5	4	HH
Washer**	AN960PD416L	AR	Commercial

\* If required

\*\* Required only when using alternate method of installing bearing attach bolts.

**MANDATORY**

# SERVICE BULLETIN

**MANDATORY MANDATORY MANDATORY**

**H. MATERIALS:**

MATERIALS	
Nomenclature	Source
Primer, zinc chromate 908-L-021 10 TT-P-1757	Glidden-Durkee Div., SCM Corp. 900 Union Commerce Bldg. Cleveland, Ohio 44115
1063-166	E.I. DuPont de Nemours Co. Marshall Laboratory 3500 Grays Ferry Ave. Philadelphia, PA 19146

**2. INSPECTION PROCEDURE**

- a. Remove swashplate assembly from helicopter (refer to Basic HMI-Vol 1, Section 7 ).
- b. Remove PN 369A7003-3 bearing assembly from swashplate assembly and clean (refer to 369D-COM, Part V, Sections 2 and 3).
- c. Inspect subject bearing assembly for cracks using the dye penetrate method, with special attention to area of bearing sleeve around four mounting holes where bearing assembly bolts to stationary swashplate.



Ensure that solution does not permeate either ball or teflon bearing.

- d. If cracks are found in bearing assembly, it must be replaced with a new bearing assembly and installed per steps f. and g. below.
- e. If no cracks are found in bearing assembly, it may be reinstalled per steps f. and g. below.

**NOTE:** If suspect indications are discovered by dye penetrate inspection, which cannot be definitely confirmed, the subject bearing assembly is to be reinspected using the magnetic particle method. After magnetic particle inspection, perform step d. or e. above.



Ensure that solution does not permeate' either ball or teflon bearing.

**MANDATORY MANDATORY MANDATORY**



# SERVICE BULLETIN

DATE: 28 JULY 1981

PAGE 3 OF 4

**MANDATORY**

f. Install original (or new) bearing assembly in swashplate assembly per 369D-COM, Part V, Section 6, except install bearing attach bolts as follows:

**NOTE:** Some bearing assemblies may have sharp edges around the mounting holes. If sharp edges have nicks, dress out using hand file or emery cloth and apply zinc chromate primer.

1. Bolts may be installed with heads facing inward by installing one PN 369A1605-5 washer under head of each bolt.

2. Bolts may be installed with heads facing outward by installing PN AN960PD416L washers as required (two maximum) under bolt head to maintain 1.5 to 2 exposed threads of bolt and a minimum of 0.100-inch distance between ball and bolt

g. Reinstall swashplate assembly on helicopter (refer to Basic HMI-Vol 1, Section 7).



If PN NAS1304-15 and NAS1304-16 bolts are used to attach bearing assembly to swashplate assembly and bolts were installed with heads facing outward (step f2 above), position controls full collective down and full forward cyclic left and full forward cyclic right. Observe if forward bolts interfere with mast. If interference occurs, repeat step a., replace PN NAS1304-15 bolt with PN NAS1104-15 bolt and PN NAS1304-16 with PN NAS1104-16 bolt and repeat step g.

h. Record compliance with this Service Information Notice in Compliance Record of helicopter Log Book.

**MANDATORY**

# SERVICE BULLETIN

MANDATORY MANDATORY MANDATORY

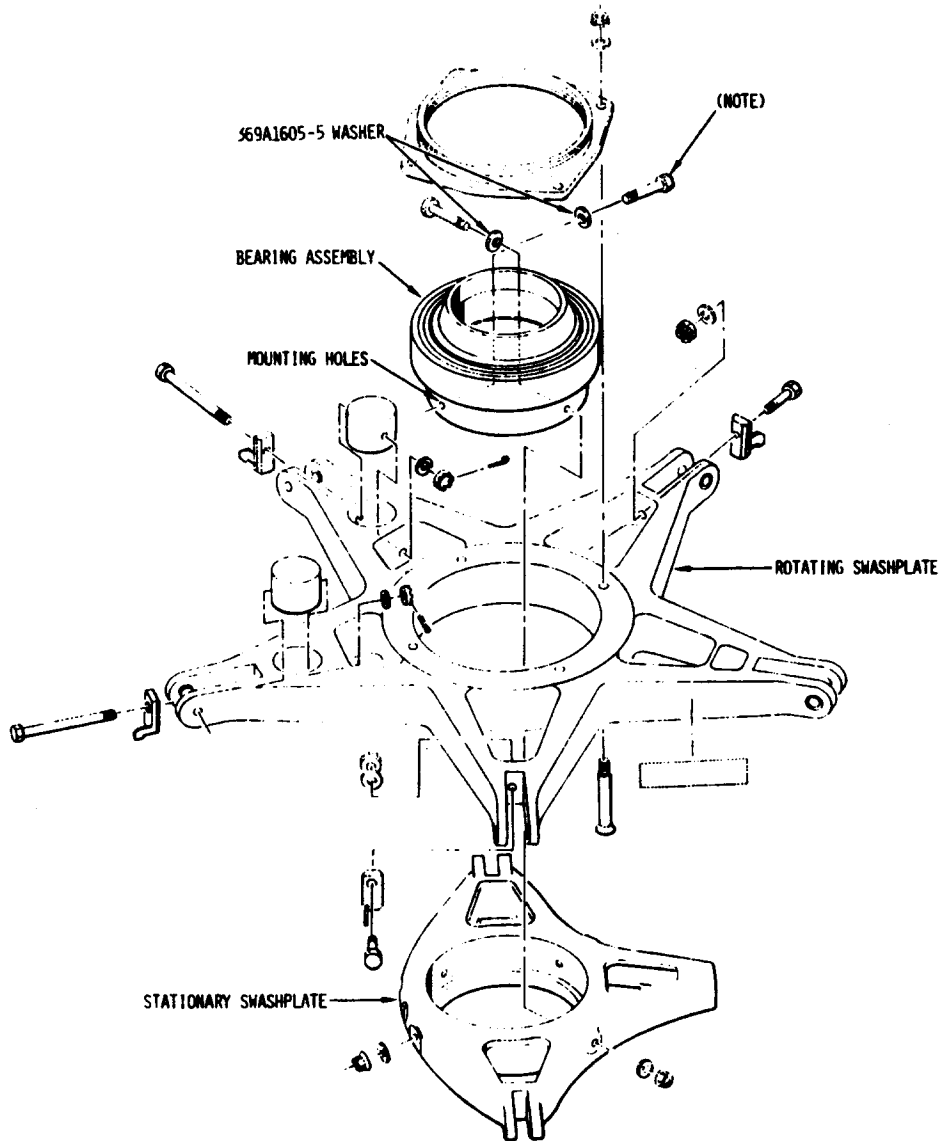

**NOTE:**  
BOLTS MAY BE INSTALLED WITH HEADS FACING INWARD AS AN ALTERNATE METHOD. REFER TO TEXT FOR INSTRUCTIONS.

88-434A

**Figure 1. Inspection of Swashplate Bearing**

MANDATORY MANDATORY MANDATORY