

MD EXPLORER®

DIMENSIONS

9.0 DIMENSIONS.

9.1 Three-view drawing.

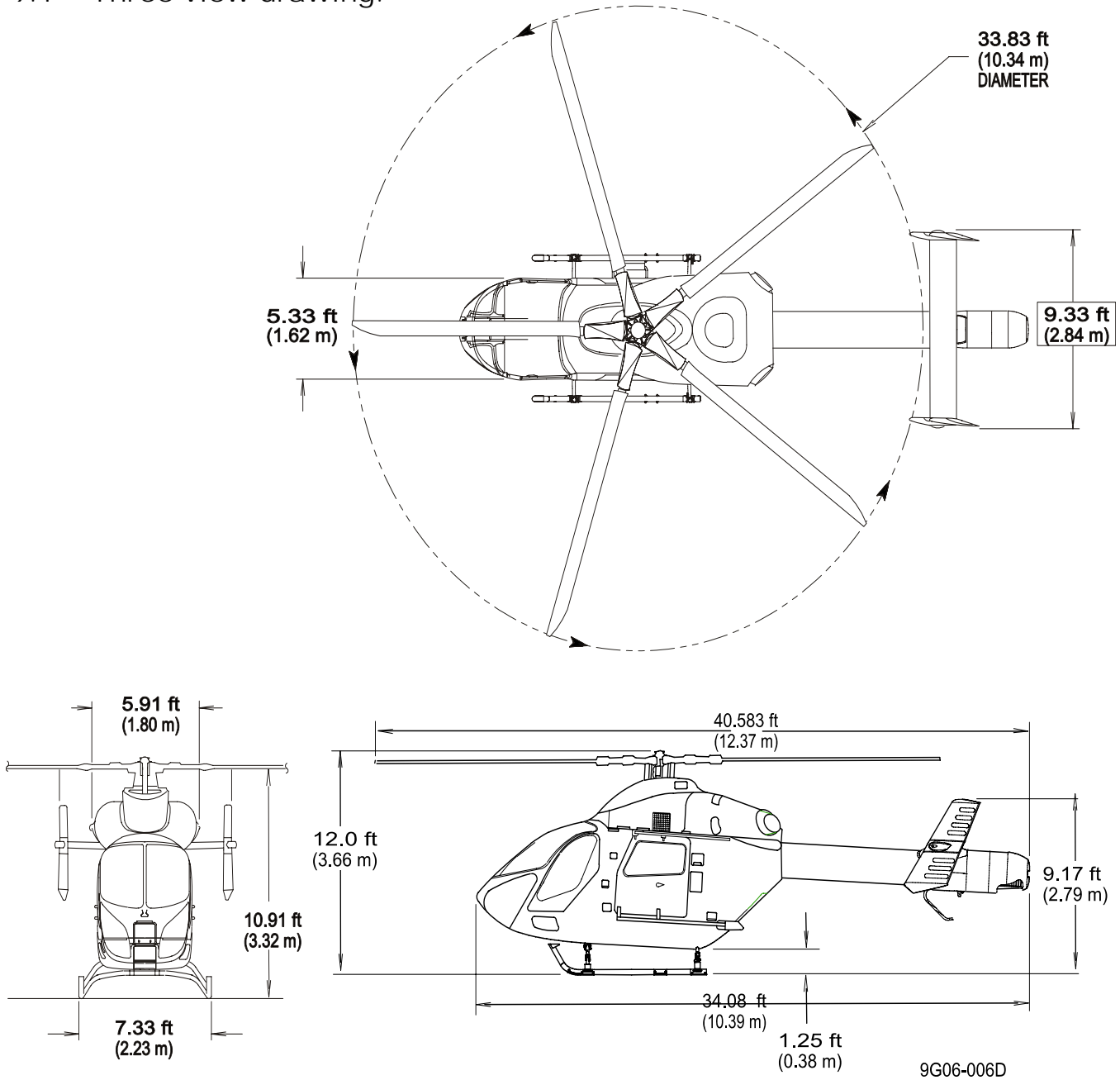

Figure 34. Three-View Drawing

MD EXPLORER®

DIMENSIONS

9.2. General Dimensions.

Fuselage:

Length.....	34.08 ft	(9.86 m)
Width.....	5.33 ft.	(1.62 m)
Height.....	12.00 ft	(3.66 m)
Ground clearance	1.25 ft.	(0.38 m)
Landing gear width.....	7.33 ft	(2.23 m)
Crew compartment (approximate)	82.4 ft ³	(2.33 m ³)

Main cabin:

Length.....	6.3 ft	(1.91 m)
Width.....	4.3 ft	(1.45 m)
Height.....	4.1 ft.	(1.24 m)
Useful floor area, cabin and baggage.....	41.0 ft ²	(3.81 m ²)
Cabin.....	30.2 ft ²	(2.23 m ²)
Baggage	10.8 ft ²	(1.00 m ²)

Volume:

Cabin.....	124.0 ft ³	(3.51 m ³)
Baggage.....	48.7 ft ³	(1.38 m ³)
Total.....	172.7 ft ³	(4.89 m ³)

Overall dimensions:

Rotor diameter.....	33.83 ft	(10.31 m)
Length, rotor turning.....	40.58 ft	(11.84 m)

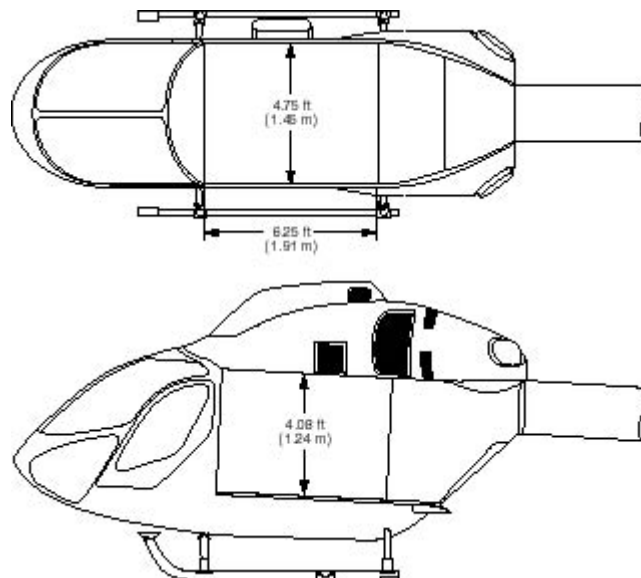

Figure 35. Main Cabin Dimensions